

# Get A Ph.D In pH Shift Odor Control



**TRANSFORMING WATER. ENRICHING LIFE.**

©2019 Evoqua Water Technologies

1

## How to Participate Today

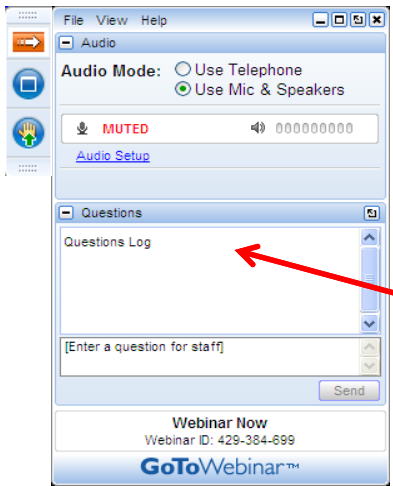

- **Audio Modes**
  - Listen using Mic & Speakers
  - Or, select "Use Telephone" and dial the conference (please remember long distance phone charges apply).
- **Submit your questions using the Questions pane.**
- **A recording will be available for replay shortly after this webcast.**



Confidential | Page 2  
©2019 Evoqua Water Technologies

2

## Your Presenters Today Are:



- Calvin Horst, Product Manager, Odor Control

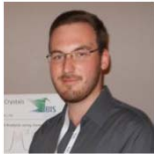

- Justin Stewart, Application Engineer, Odor Control

3

## pH Shift Odor Control - Outline

- **Wastewater Odors**
  - What are they and where do they come from
- **pH Shift Odor Control**
  - Methodology
  - Products – Characteristics / Pros / Cons
- **Case Study**
  - Method
  - Results



4

## Odorous Compounds

Substance	Formula	Characteristic Odor	Odor Threshold (ppm)
Allyl Mercaptan	$\text{CH}_2=\text{CH}-\text{CH}_2-\text{SH}$	Strong garlic-coffee	0.00005
Amyl Mercaptan	$\text{CH}_3(\text{CH}_2)_3-\text{CH}_2-\text{SH}$	Unpleasant-putrid	0.0003
Benzyl Mercaptan	$\text{C}_6\text{H}_5\text{CH}_2-\text{SH}$	Unpleasant-strong	0.0002
Crotyl Mercaptan	$\text{CH}_3-\text{CH}=\text{CH}-\text{CH}_2-\text{SH}$	Skunk-like	0.00003
Dimethyl Sulfide	$\text{CH}_3-\text{S}-\text{CH}_3$	Decayed vegetables	0.0001
Ethyl Mercaptan	$\text{CH}_3\text{CH}_2-\text{SH}$	Decayed cabbage	0.0002
Hydrogen Sulfide	$\text{H}_2\text{S}$	Rotten Eggs	0.0005
Methyl Mercaptan	$\text{CH}_3\text{SH}$	Decayed cabbage	0.0011
Propyl Mercaptan	$\text{CH}_3-\text{CH}_2-\text{CH}_2-\text{SH}$	Unpleasant	0.000075
Sulfur Dioxide	$\text{SO}_2$	Pungent, irritating	0.009
Tert-Butyl Mercaptan	$(\text{CH}_3)_3\text{C}-\text{SH}$	Skunk, unpleasant	0.00008
Thiocresol	$\text{CH}_3-\text{C}_6\text{H}_4-\text{SH}$	Skunk, rancid	0.00006
Thiophenol	$\text{C}_6\text{H}_5\text{SH}$	Putrid, garlic like	0.00006
Amines	$\text{CH}_3\text{NH}_2, (\text{CH}_3)_2\text{N}$	Fishy	0.035, 0.000032
Ammonia	$\text{NH}_3$	Ammoniacal	1.5
Diamines (cadaverine)	$\text{NH}_2(\text{CH}_2)_n\text{NH}_2$	Decayed Flesh	-
Skatole	$\text{C}_8\text{H}_9\text{NHCH}_3$	Fecal	0.0000056

5

## Hydrogen Sulfide – Generation – Mechanism

- When any liquid flows through a pipe, the fastest flow speed is at the center of the pipe.
- Toward the pipe wall, liquid flows in concentric, progressively slower, flow-speed layers.
- The slowest flow-speed layer, called the boundary layer, is next to a stagnant (no-flow) layer at the pipe wall.

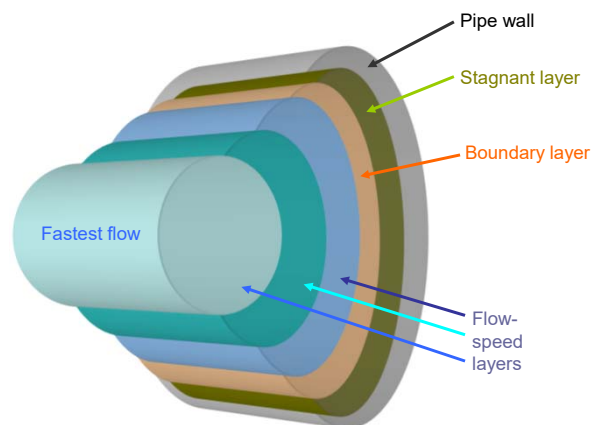

6

## Hydrogen Sulfide – Generation – Mechanism

- Natural-occurring bacteria grow in the stagnant layer and feed on the sewage that migrates through the boundary layer.

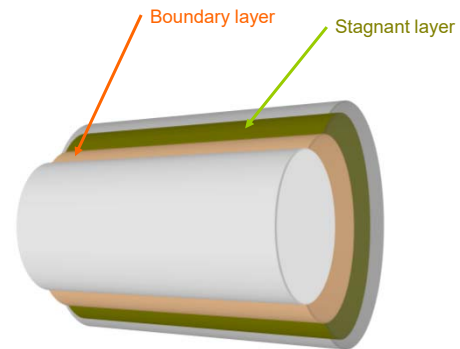

7

## Hydrogen Sulfide – Generation – Mechanism

- The type of bacteria depends on the availability of oxygen:
  - In an oxygenated environment, the bacteria are aerobic; they “breathe” oxygen ( $O_2$ ) and release carbon dioxide ( $CO_2$ ).

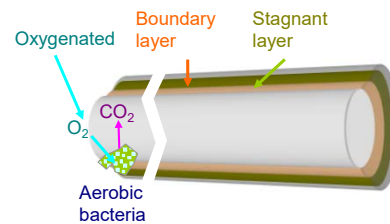

8

## Hydrogen Sulfide – Generation – Mechanism

- In long sewage pipes, oxygen consumption by aerobic bacteria in the upstream segment creates an oxygen-depleted zone in the downstream segment, in which anaerobic bacteria thrive.

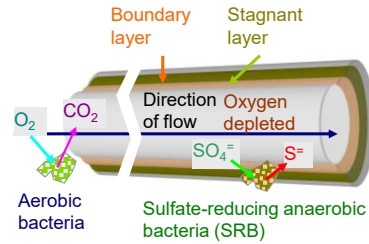

9

## Hydrogen Sulfide – Generation – Mechanism

- The type of bacteria depends on the availability of oxygen:
  - Anaerobic sulfate-reducing bacteria (SRB) form in an oxygen-depleted environment.
  - In such an environment, SRB “inhale” sulfate ( $\text{SO}_4^-$ ) and “exhale” sulfide ( $\text{S}^-$ ).

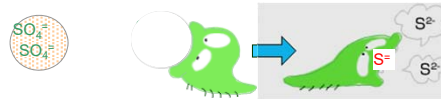
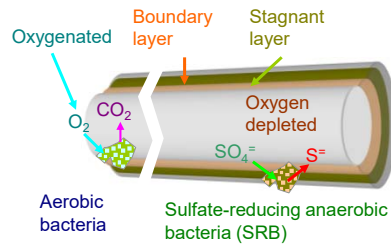

10

## Sulfide – pH Ionization relationship

Sulfide in solution exists in 1 of 3 forms:

- Dissolved hydrogen sulfide gas ( $\text{H}_2\text{S}$ )
- Bisulfide ( $\text{HS}^-$ )
- Sulfide ( $\text{S}^{2-}$ )

Of these 3  $\text{H}_2\text{S}$  is volatile and can be liberated through turbulence.

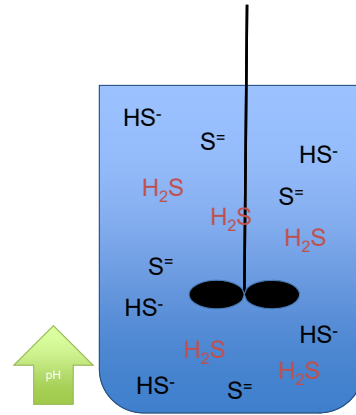

11

## Sulfide – pH Ionization relationship

Sulfide in solution exists in 1 of 3 forms:

- Dissolved hydrogen sulfide gas ( $\text{H}_2\text{S}$ )
- Bisulfide ( $\text{HS}^-$ )
- Sulfide ( $\text{S}^{2-}$ )

Of these 3  $\text{H}_2\text{S}$  is volatile and can be liberated through turbulence.

The prevailing form depends on pH.

As pH increases,  $\text{H}_2\text{S}$  shifts to one of the two non-volatile ionic forms.

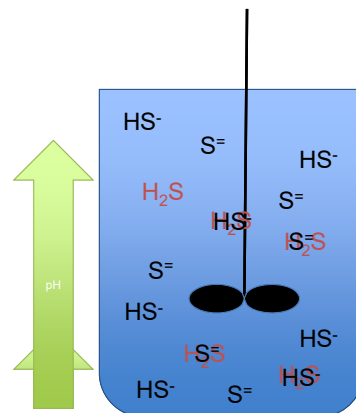

12

## pH Shift Odor Control - Overview

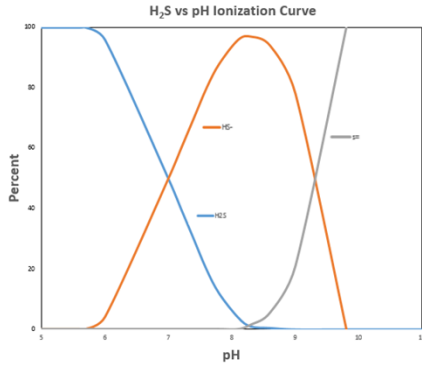

- S<sup>2-</sup> : non-volatile
- HS<sup>-</sup> : non-volatile
- H<sub>2</sub>S : volatile, can off-gas to cause corrosion and odors.

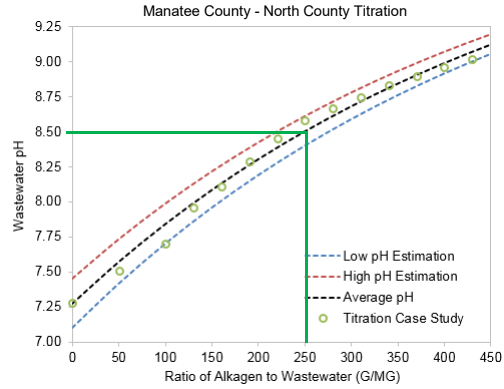

Dosing is based on wastewater flow rate, NOT H<sub>2</sub>S concentrations



13

## pH SHIFT PRODUCT OPTIONS

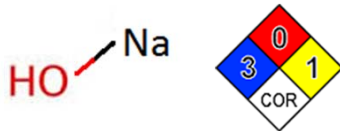

### Characteristics

- Solubility 109 g/L
- Does not self buffer
- Does not contribute to the formation of Struvite
- Highly Corrosive
- High/Serious Health Hazard

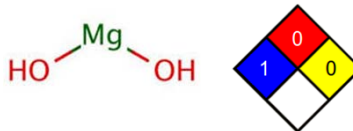

### Characteristics

- Non-Hazardous
- Self Buffering
- Self Buffering to 8.5
- Slurry can accumulate if overfed
- Difficult to monitor for overfeed
- Contributes to the formation of Struvite

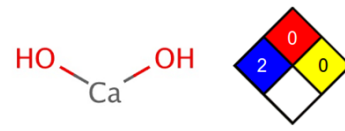

### Characteristics

- Wide pH range\controllable
- Dissolves rapidly
- Doesn't form Struvite
- Slurry can accumulate if overfed
- Can cause scaling if overfed



14

## Case Study – Wastewater Treatment Plant – Southern Florida

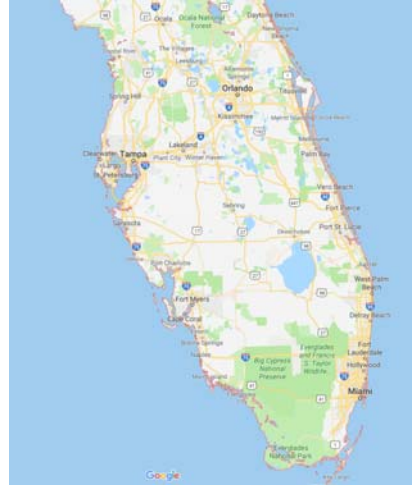

Confidential | Page 15  
©2019 Evoqua Water Technologies

## Case Study – Wastewater Treatment Plant – Southern Florida



Confidential | Page 16  
©2019 Evoqua Water Technologies



## Case Study – Scrubber Performance

- This WWTP is located in a high profile tourist district.
- Complaints were received regarding “rotten egg” odors around the plant.
- Headworks covers and EQ tank was confirmed to be airtight. Scrubber was air-balanced.
- Odor complaints persisted. Scrubber was unable to completely remove H<sub>2</sub>S.

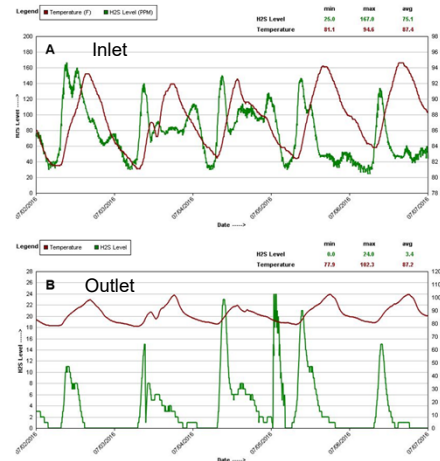

17

## Case Study - Wastewater Treatment Plant – Southern Florida



- Plant scheduled to be decommissioned and converted to a Master Pump Station by 2018.
- Needed a temporary solution for controlling H<sub>2</sub>S odors from the scrubber effluent.
- Solution should be:
  - Not cost – prohibitive or capital intensive
  - Mobilized quickly / provide immediate results
- Liquid phase odor control via. temporary feed system deemed most economical solution.

18

## Methods – Technology Evaluation

• Design Considerations / Limitations:

- Upstream lift stations lack physical space for installation of chemical feed systems.
- Upstream lift stations are located in sensitive tourist or residential areas.
- Feed system must be able to control odors by feeding chemical at the WWTP.
- Chemical safety is a concern / non hazardous chemicals preferred.

Upstream Lift Station	Flow (ML/d)	Length (m)	Size (cm)	Avg. RT (hrs)
Lift Station #1	0.999	604.4	15.2	0.3
Lift Station #2	0.625	430.7	15.2	0.3
Lift Station #3	1.110	976.6	20.3	0.7
Lift Station #4	0.814	958.6	15.2	0.5
Lift Station #5	0.625	430.7	15.2	0.3
Lift Station #6	0.386	1003.1	15.2	1.1
Average				0.5

• Nitrate Salts: Calcium Nitrate Solution

- 1.5 hour RT for complete removal
- Requires feed system upstream in collection system

• Iron Salts: Ferric / Ferrous Sulfate Solutions

- ~ 5 minutes RT for complete reaction
- Chemical safety is a concern

• Oxidizers: Hydrogen Peroxide Solution

- ~ 30 minutes RT for complete removal
- Chemical safety is a concern

• pH Shift: Calcium / Magnesium Hydroxide

- Ca(OH)<sub>2</sub> dissolves rapidly
- Mg(OH)<sub>2</sub> requires > 30 minutes to completely dissolve

## Methods – Chemical Feed Equipment

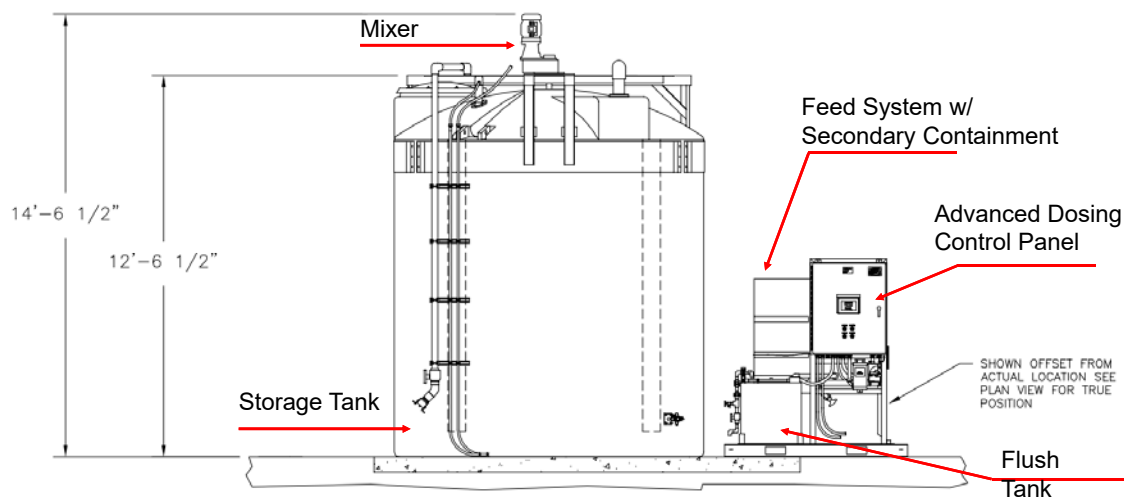

## Methods – Chemical Feed Equipment



21

## Dose Curve vs. Two Pump Two Timer

- Two Pump Two Timer (2P2T) systems attempt to satisfy changing chemical demand by using three set feed rates:
  - Only Pump 1 On
  - Only Pump 2 On
  - Both Pump 1 and Pump 2 On
- Many parts of the day are either overfed or underfed.
- Requires overshooting feed rates in order to achieve 100% sulfide control.
- “Best Fit” 2P2T settings to meet the daily Chemical demand

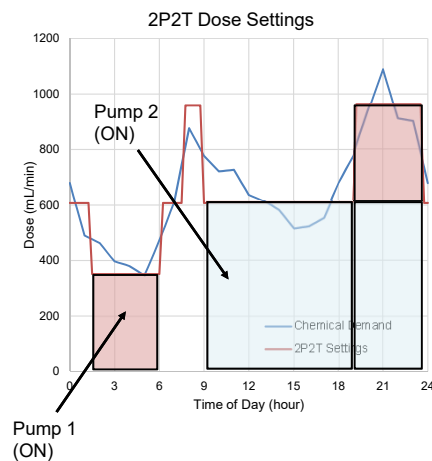

22

### Advanced Dosing / Remote Monitoring

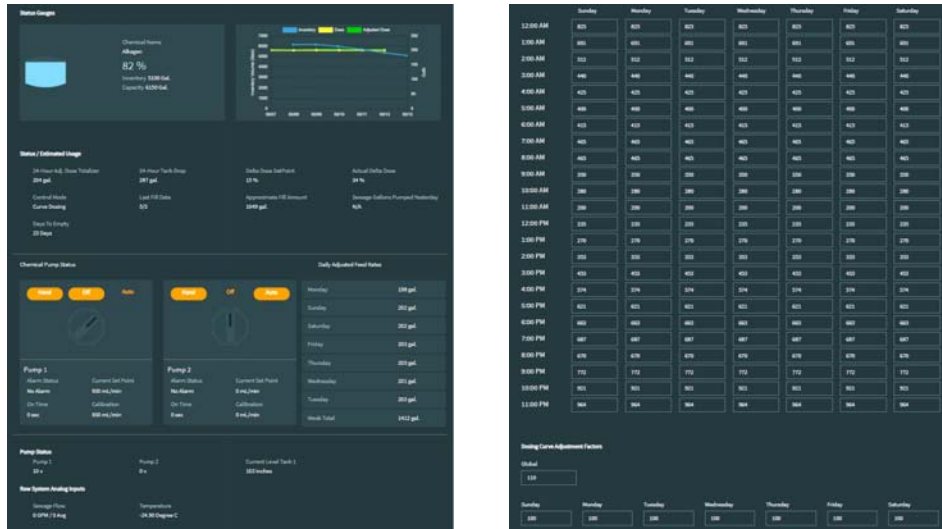

23

### Advanced Dosing / Remote Monitoring

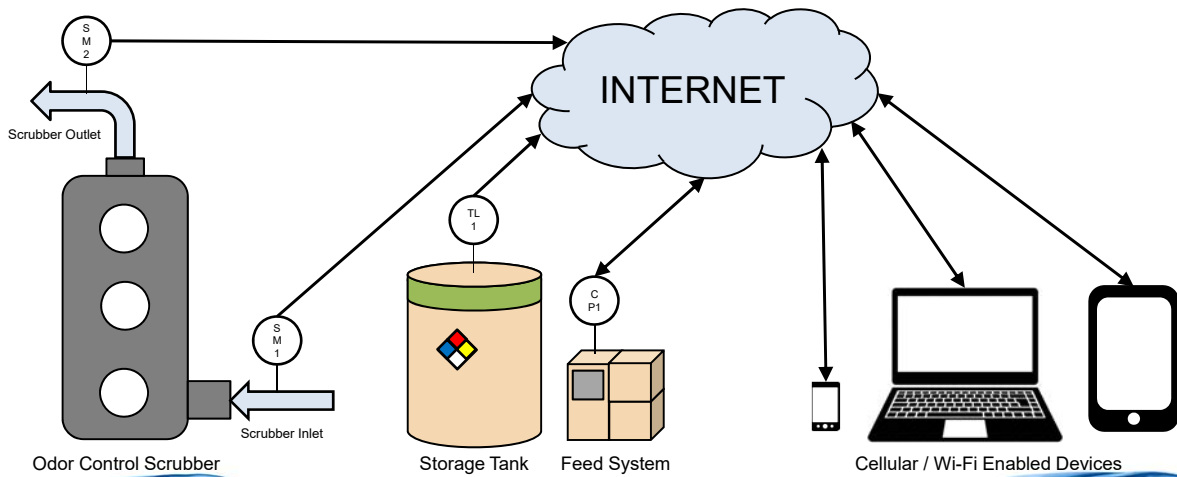

24

## Treatment Objective

- Plant ADF: 4.9 ML/d (1.3 MGD)
- Untreated Conditions:
  - Average Atmospheric H<sub>2</sub>S (Inlet): 75 ppm<sub>v</sub>
  - Average Atmospheric H<sub>2</sub>S (Outlet): 3.4 ppm<sub>v</sub>
  - Average Wastewater pH (headworks): 7.4
- Treatment Objective:
  - Average Atmospheric H<sub>2</sub>S (Inlet): ≤ 10 ppm<sub>v</sub>
  - Average Atmospheric H<sub>2</sub>S (Outlet): ≤ 0.5 ppm<sub>v</sub>
  - Average Wastewater pH (headworks): 8.3 – 8.5



25

## Treatment Objective – Dose Estimation

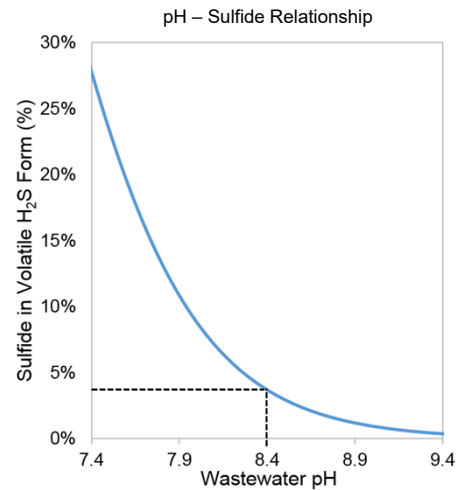
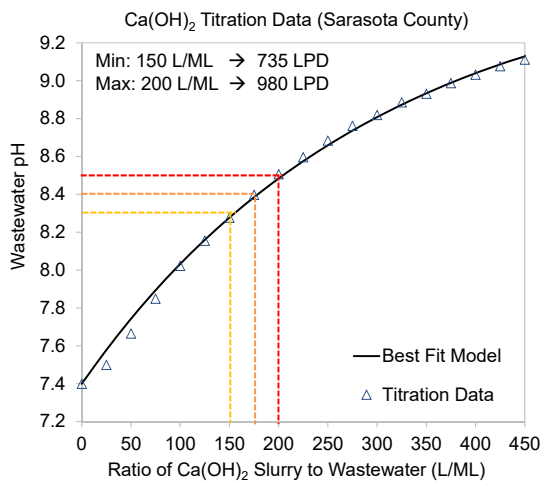

26

### Results – Hydrogen Sulfide Concentrations

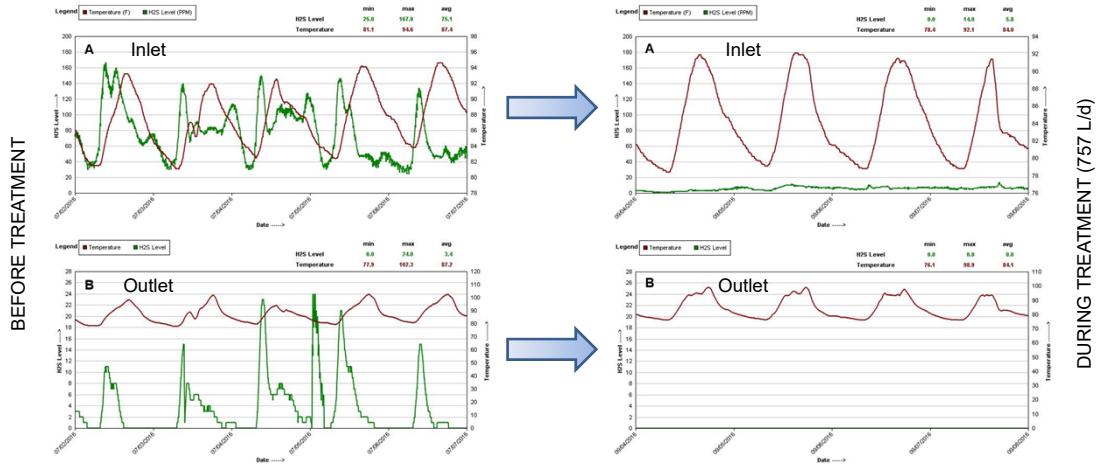

27

### Results – Final Dose Curve / Treated pH

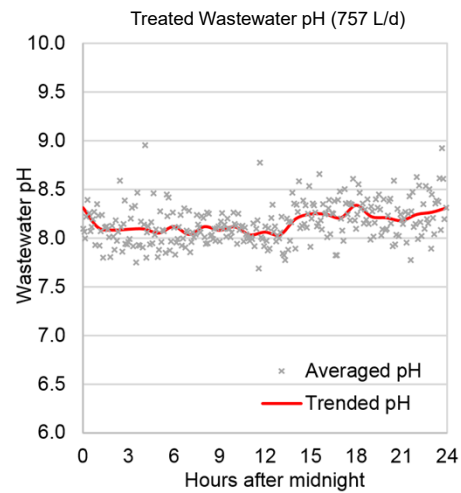
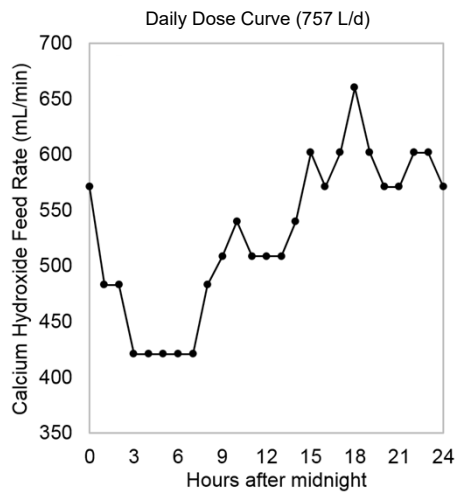

28

## Results - Summary

- Plant ADF: 4.9 ML/d (1.3 MGD)
- Treatment Objective:
  - Predicted Daily Feed Rate: **735 - 980 L/d (195 - 260 GPD)**
  - Average Atmospheric H<sub>2</sub>S (Inlet): **≤ 10 ppm<sub>v</sub>**
  - Average Atmospheric H<sub>2</sub>S (Outlet): **≤ 0.5 ppm<sub>v</sub>**
  - Average Wastewater pH (headworks): **8.3 – 8.5**
- Results:
  - Actual Daily Feed Rate: **757 L/d (200 GPD)**
  - Average Atmospheric H<sub>2</sub>S (Inlet): **5.8 ppm<sub>v</sub>**
  - Average Atmospheric H<sub>2</sub>S (Outlet): **0 ppm<sub>v</sub>**
  - Average Wastewater pH (headworks): **8.2**

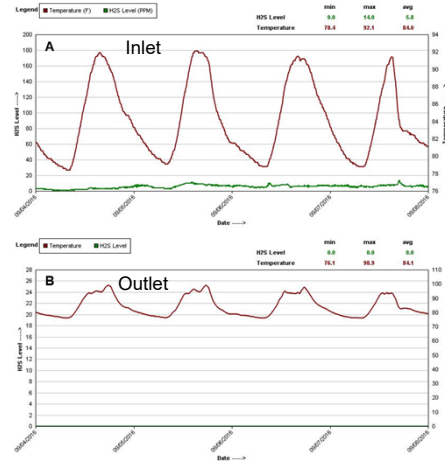

29

## Discussion / Conclusions

- By using a Calcium Hydroxide slurry, the Southern Florida WWTP was able to reduce H<sub>2</sub>S loadings.
- H<sub>2</sub>S levels were reduced such that the plants aging scrubber was able to handle any residual odors.
- Calcium Hydroxide slurry could be applied directly into WWTP influent flow at the plant headworks.
- Rapid dissolution of Calcium Hydroxide allowed for an instantaneous reduction of odors.
- Average pH was elevated from 7.4 to approximately 8.2 by feeding 757 L/d (200 GPD)
- Final optimized feed rates were actually less than what was originally predicted from initial titration / model data.
- Following this successful demonstration, the customer continued to treat the WWTP using Calcium Hydroxide.

30

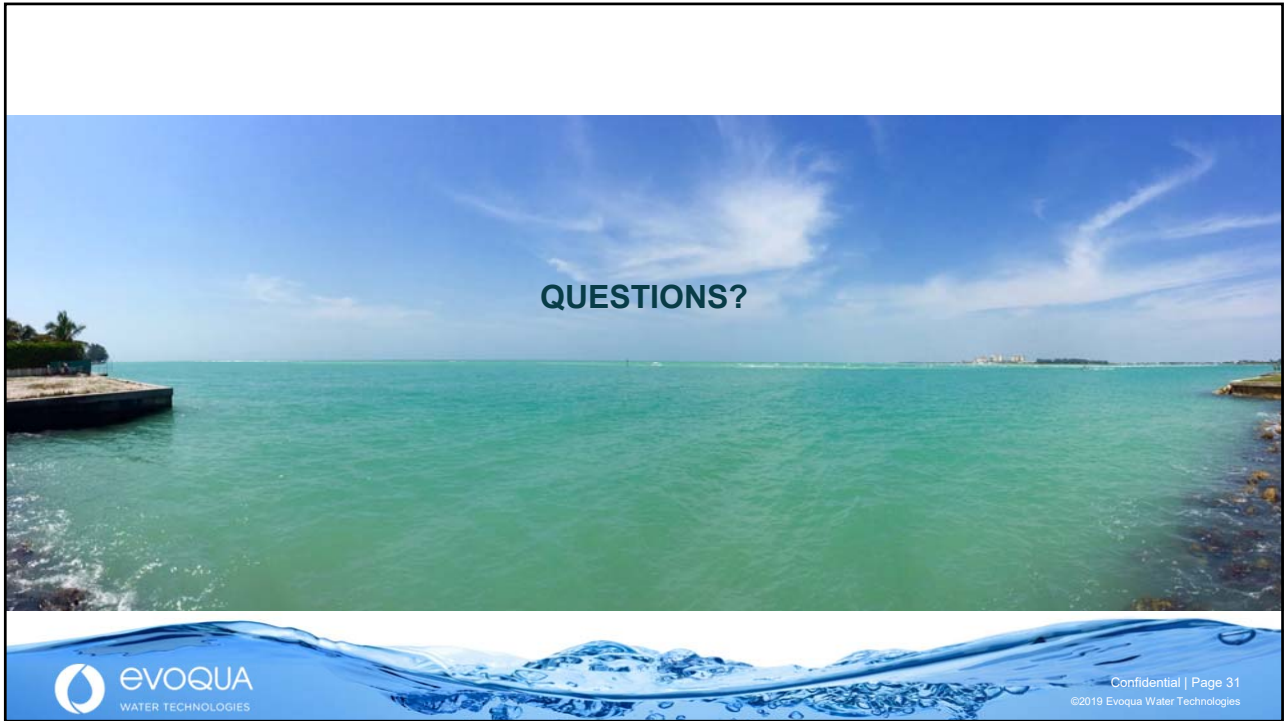

31



32



## Header (Arial 24)

Text: Arial 18 or smaller, depending on amount of content.

Do not cover the footer or logo and wave with text.

*Callouts: Arial 20 (if possible), bold, italicized; white font on blue background. Callout box should be no wider than text box on the page.*



Confidential | Page 33  
©2019 Evoqua Water Technologies