

INCREASE PUMP STATION EFFICIENCY DECREASE LIFE CYCLE COSTS

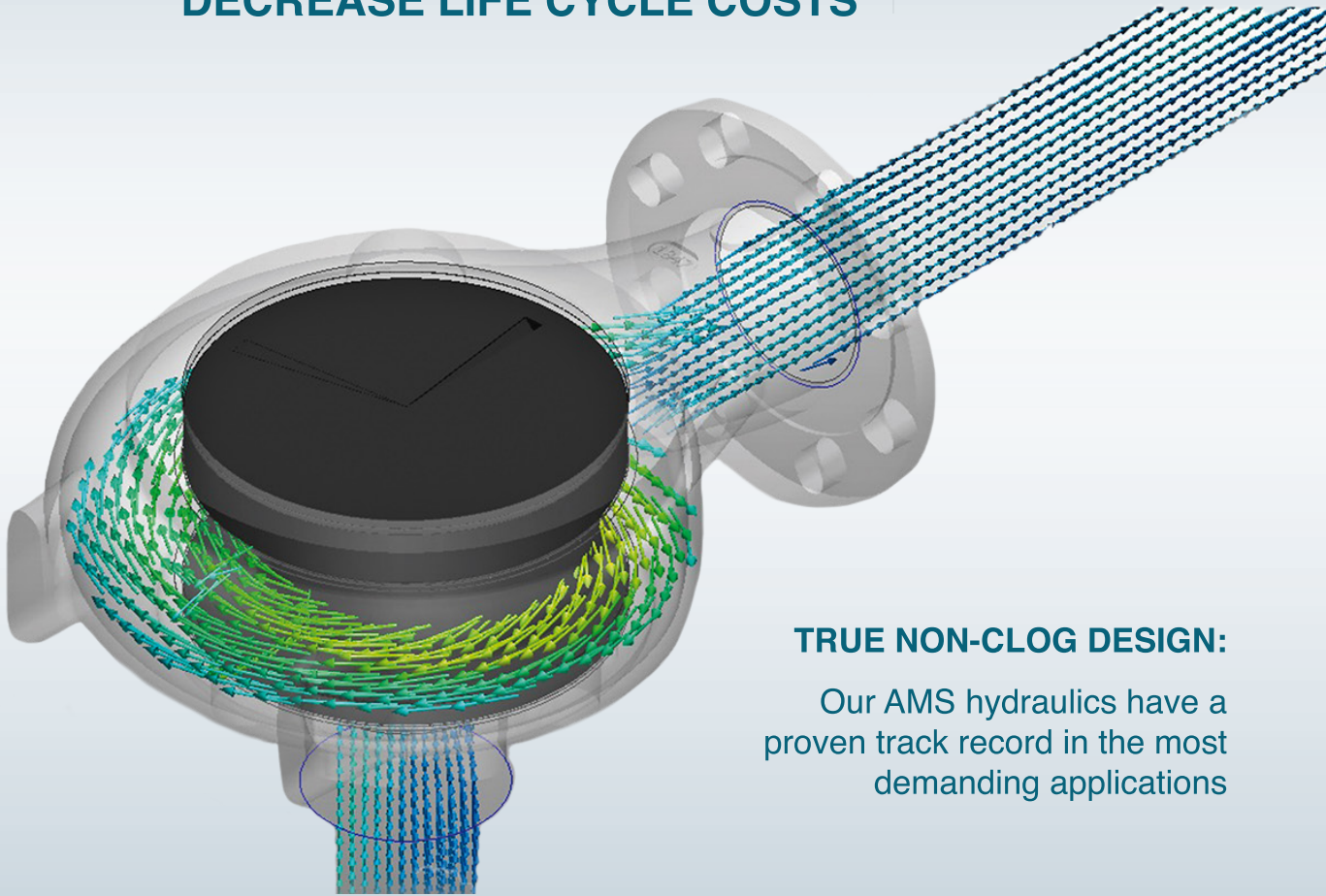

TRUE NON-CLOG DESIGN:

Our AMS hydraulics have a proven track record in the most demanding applications

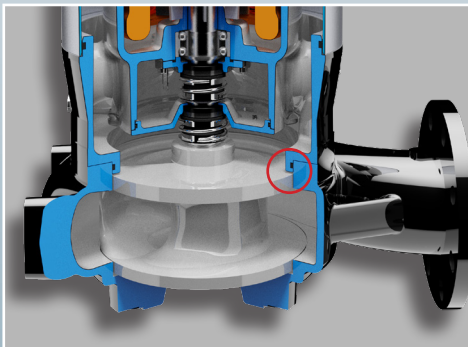

CONTROLLED RADIAL TOLERANCE: No frequent, expensive maintenance or adjustments required

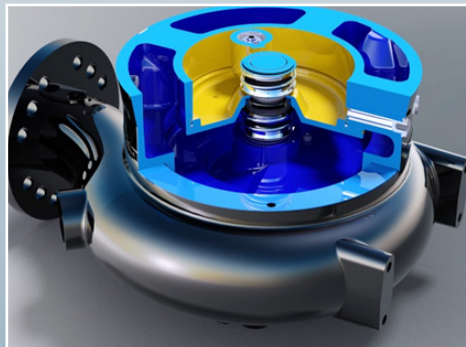

PERMACOOL™: Our patented cooling system design eliminates jacket clogs



FLEXIBILITY: HOMA is able to match industry guarantees and warranties upon request