

## Advancing Environmental Innovation

## Helping customers separate solids from wastewater more efficiently

### *Centrisys supports global sustainability*

Worldwide, we must find every possible way to manage water resources more efficiently. That makes municipal and industrial wastewater innovation urgent and companies like Centrisys essential. For over three decades, Centrisys Corporation has advanced decanter centrifuge innovation for water, wastewater and solids separation.

Since 1987, Centrisys has provided centrifuge equipment repair and maintenance. The company evolved as a technical leader by designing, engineering and building decanter equipment for sludge dewatering and thickening. Centrisys applies its deep technology understanding to produce breakthroughs that continue to improve efficiency, safety and performance.

#### Engineered, Designed and Manufactured in the U.S.A.

Based in Kenosha, Wisconsin, Centrisys is the only U.S.A. manufacturer of decanter centrifuges for municipal water and wastewater applications and one of the few companies in the world focused solely on this centrifuge technology. This niche emphasis gives the company room to systematically pursue new markets, industries and customers while bringing crucial innovations that support cleaning wastewater around the world.

Centrisys founder and CEO Michael Kopper leads a team of engineers from diverse disciplines. They bring fresh perspectives, continuous learning and collaborate together to tackle the toughest challenges in the industry.

#### Resource Intensification Portfolio

In 2014, Centrisys launched CNP – Technology Water and Biosolids Corporation to design and supply systems for nutrient recovery and sludge optimization. Together, Centrisys/CNP systematically expanded their offerings to include innovative technologies that are relevant for resource recovery and process intensification.

- 2014: **AirPrex®** is a post-digestion P-recovery process that turns dissolved nutrients into struvite crystals, which can be used as a slow releasing fertilizer when harvested and utilized separately (*exclusive North American distributor*)
- 2014: **PONDUS™** is a Thermo-Chemical Hydrolysis Process (TCHP) that increases biogas production and digester capacity, while reducing sludge volume and polymer consumption (*exclusive North America distributorship*)
- 2016: **Sulzle Klein GmbH**, is a low-temperature belt dryer manufacturer (*exclusive North American distributor*)
- 2017: **Lipp GmbH** is a digester and storage tanks manufacturer (*exclusive North American distributor*)
- 2017: **CalPrex™** is a pre-digestion P-recovery process that recovers phosphorus as a brushite, which can be used as a fertilizer (*exclusive worldwide licensing*)
- 2018: **Passavant® Variable Inlet System hydrograv® adapt** is an inlet system that adjusts loading to fluctuations in a secondary clarifier (*exclusive North American distributor*)

## Centrisys at a Glance

#### Industry Applications

- Municipal and industrial water and wastewater
- Food and beverage
- Fish, meat and poultry
- Animal manure
- Agricultural
- Pulp and paper
- Chemical processing
- Biofuels
- Oil and gas drilling
- Mining and tunneling

#### Company Leadership

- Michael Kopper, C.E.O. and Founder
- Gerhard Forstner, CNP North America President
- George Kueppers, VP of Production
- James Andresen, Chief Operating Officer
- Luis Garza, Mechanical Engineering Director
- Geoff Harvey, Electrical Engineering Director
- Robert Greidanus, Manufacturing Director
- Robert Havrin, Process Engineering Director

#### Facilities & Locations

- Kenosha, Wisconsin – Corporate Headquarters
  - Production
  - Repair and service
- Stockton, California – repair and service
- Lufkin, Texas – repair and service
- Brazil, South America
- Oftersheim, Germany – repair and service
- Abu Dabi, U.A.E.
- Chengdu, China – partnership with Tian Bau for production, sales, repair and service
- Global support centers

## Advancing Environmental Innovation

## Continuous Innovations Gain Industry Leaders Attention

Many organizations recognize Centrisys for its valuable innovation leadership. Lead engineering firms analyze and publish wastewater separation technologies recommendations from Centrisys. Cities like Kenosha, Wisconsin have an international reputation for being ahead of the curve in wastewater and water treatment. New York City, Denver, Austin, Seattle, Cleveland and Fresno choose Centrisys centrifuges based on careful consideration of the proven advantages. Beijing, China, one of the world's largest wastewater treatment plants, installed 16 THK600 Thickening Centrifuges to help reduce their biosolids footprint.

### The Centrisys portfolio includes:

- **CS Series:** available from 6- to 44-inch machines, the 2- and 3-phase decanter centrifuges deliver the highest torque with the lowest horsepower; has lower operating and maintenance costs and delivers increased solids handling with higher flow rates
- **DT Series:** the first decanter centrifuge developed specifically for the manure industry; removes suspended solids and nutrients from manure slurry which allows producers to haul less and utilize recovered solids
- **T Series:** a shallow beach centrifuge for mineral applications, mining, tunneling, oil and gas



DingFuZhuang WWTP Beijing, China: Five Centrisys THK600 and four CS21-4HC.

- **THK Series:** a thickener designed specifically for sludge thickening, available in three sizes: 200, 350 and 600. The THK sludge thickener design uses little to no polymer, optimizes flow rates and significantly reduces floor space requirements and treatment plant odors

Centrisys continues to build on this momentum, seeking new ways to maximize uptime, efficiency and performance in biosolids technology while supporting global efforts to better manage resources along the way.



**Reduce Energy Use:** Centrisys was the first to design decanter centrifuges with advanced hydraulic scroll drives as a standard. The Viscotherm Rotodiff® back drive provides the highest torque to weight ratio, 100 percent torque at all speeds and low energy consumption. This hydraulic back drive technology saves energy costs for over 2,000 Centrisys customers worldwide.

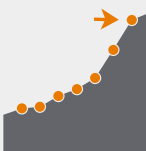

**Maximize Performance:** Centrisys designed its first centrifuge based on rigorous analysis and testing to ensure high performance and durability. Incorporating the Rotodiff® technology, corrosion-resistant duplex stainless steel, centrifugally cast components and an optimal beach angle of 15 degrees, the centrifuge delivers superior performance. The very first Centrisys dewatering centrifuges, installed 1989 in Honolulu, are still going strong today.



**Service and Repair Capabilities:** The ability to service ALL makes, models and brands of decanter centrifuges allows Centrisys to help you get the most out of your equipment. The service department provides data, training and engineering expertise to efficiently repair centrifuges across a range of applications, while accessing maintenance parts housed at our U.S.A. service centers.

## Questions about Centrisys technologies?

**Corporate** 9586 58th Place | Kenosha, WI 53144 USA P +1 (262) 654-6006 E [info@centrisys.com](mailto:info@centrisys.com)  
**Global Presence** North America | South America | Europe | Middle East | China



ISO 9001:2015



# 9 Reasons to Choose Centrisys

*The major features and benefits of a Centrisys Centrifuge*

## 1 U.S.A. Engineering and Design

### *Built from the Ground Up*

By way of passionate drive and ambitious character, Michael Kopper began a mission to create the most efficient decanter centrifuge in the industry. In 1987, the first Centrisys centrifuge was designed and built around what was learned in the field by servicing competitor's equipment in both municipal and industrial applications.

Thirty years later, the Centrisys engineering team continues to benefit from problem-solving and learning what does and does not work in the real world. They take that knowledge and continue Centrisys' lifelong commitment to brand excellence. A Centrisys centrifuge is designed, engineered and built with pride at our corporate headquarters in Kenosha, Wisconsin.



## 2 Highest Quality

### *A Standard, Not an Option*

- All structural rotor components are centrifugally cast\* or forged for ultimate integrity and strength

- Centrifugally cast bowls are made of A890 duplex stainless steel, offering substantially higher tensile strength and greater corrosion resistance compared to 316SS

*\*Centrifugally cast components are corrosion and defect free; able to withstand greater overload and strain; enabling higher operating speeds for improved process performance.*

## 3 Automatic Hydraulic Scroll Drive

### *The Most Efficient Backdrive in the Industry*

- Highest torque to weight ratio
- 100% torque at all speeds (including standstill)
- Low weight
- Reliable/durable
- Increased solids loading capacity
- Low energy consumption (power is not lost or wasted)
- Versatile design for multiple applications
- Simple and accurate measurement of scroll speed
- Lowest overhanging load – lighter weight equals less stress on the main bearings



Refer to the *Centrisys Hydraulic Scroll Drive Brochure* to review advantages of a hydraulic back drive vs. the gear box design.



## 9 Reasons to Choose Centrisys

### 4 Advanced Wear Protection

*Standard on all Centrisys Centrifuges*

**Why is this important?** It prolongs the life of the centrifuge, increases uptime, optimizes performance and reduces service and maintenance costs.

- Scroll flight tips in a high solids area are protected with replaceable tungsten carbide tiles and offer the highest wear protection possible
- Feed acceleration nozzles are made of replaceable tungsten carbide offering the highest degree of toughness
- Bowl is protected by longitudinal wear strips allowing the solids layer to anchor between the strips and provides optimal protection from wear on the bowl
- Tungsten carbide replaceable cake discharge nozzles minimize repair and/or replacement

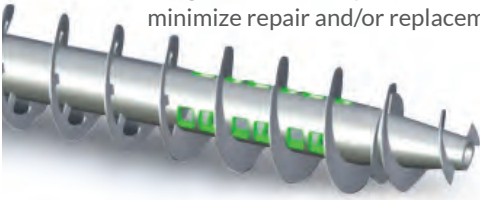

### 5 Scroll Design and Development

- Ultra-deep pool with a narrow scroll body
- Removes dewatered solids at a controlled rate to preserve equilibrium and maintain solids balance
- Incorporates an axial flow design, which promotes settling of even the finest solids, improves the recovery rate and reduces polymer consumption
- High flow design = larger and more feed ports, allowing for efficient and gentle acceleration of the treated sludge
- Leading and lagging rotational scroll optimizes performance and increases the time frame needed between service

### 6 Optimum Beach Angle\*\*

Two machines with the same length and diameter, but with different beach angles, offer different capacities.

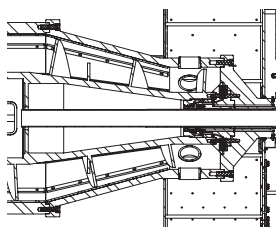

- A shallow beach has a longer cylinder, creating more clarification volume
- A steeper beach gives greater capacity provided all solids can convey up the beach while maintaining a high bowl speed and G forces

*Over the years, Centrisys tested various bowl angles from 8-90 degrees and established that a 15 degree angle is optimum for typical municipal wastewater applications. A mineral or mining dewatering process require a shallow beach angle of 8-10 degrees.*

### 7 L/D Ratio\*\*

The "L/D ratio" is the overall internal bowl length divided by the bowl inside diameter in the cylinder.

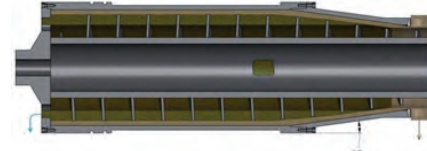

3 : 1 LD Ratio

- Machines that have a smaller L/D ratio are better suited for processes that have high specific gravity solids that settle well

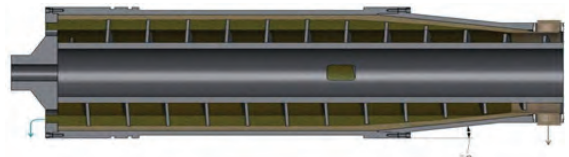

4 : 1 LD Ratio

- Machines with higher L/D ratios are better suited for lighter solids that need more time to settle from the liquid phase

*\*\*The Centrisys engineering teams consult with customers, conduct field and lab testing as well as analyze performance data to determine the optimal beach and L/D ratio for each application.*

### 8 Centrifuge Energy Recovery System (CERS)

CERS is a self-contained system using variable frequency drives on both the main drive motor and the backdrive. The drives function independently, under normal circumstances, and support each other in the case of a power outage. During a power outage, the centrifuge continues to empty preventing a costly dis-mantle to free-up a blockage. If power returns during shutdown, the centrifuge can re-start on the fly. Benefits include:

- Reduced main drive and backdrive horsepower, up to 25% reduction)
- Increased reliability and on-line process time, +10 points
- Improved handling of power disruptions

### 9 Remote Monitoring System

The Centrisys Remote Monitoring System is a proprietary remote solution. It provides 24/7, real-time text and email alerts for equipment status changes and process variations within the system. The system provides timely insights to ensure peak performance, the highest reliability and lowest operating costs.

## Questions about Centrisys technologies?

**Corporate** 9586 58th Place | Kenosha, WI 53144 USA P +1 (262) 654-6006 E [info@centrisys.com](mailto:info@centrisys.com)

**Global Presence** North America | South America | Europe | Middle East | China



ISO 9001:2015



# Get More from your Centrifuge

*Discover Centrisys' Vast Centrifuge Capabilities and Services*

## Skid, Mobile and Containerized Systems\*

Complete sludge dewatering and/or thickening solutions on a single platform. This modular approach streamlines the installation process and allows for fast and easy placement. Within a few hours, a skid system can be on site and fully operational.

*\*The Centrisys engineering team starts with a site plan, general specifications and flow diagrams to design a working system. State-of-the-art engineering programs prepare the electric schematics, PID diagrams, process drawings and control programs. All ancillary components are selected for the site specific performance and reliability.*

- Only power and process connections needed for system start-up
- Ranging from 5-700 gpm (1- 90 m3/h)
- All parts and components are covered under the Centrisys standard warranty terms and conditions



## Rentals for Dewatering and Thickening

Two- and 3-phase rental skid systems are available for seasonal and emergency needs. Short and long term leasing options are also available for dewatering and thickening. Ancillary heating systems are available as an add-on option.

## Customized Solutions a Key Strength

Centrisys provides a full range of custom engineering and manufacturing services. Our customization process starts with listening to our customers to understand their goals or challenges; analysis and development of a preliminary design; prototyping and testing to the final design – all done by our in-house engineering teams located in Kenosha, Wisconsin. Our custom solutions range in size from as large as a complete mobile system to as small as a wear component or part.

## Pilot and Lab Testing

Centrisys invested in trailer and skid mounted centrifuge systems for dewatering and thickening pilot tests. Our dedicated process engineering department conducts pilot and lab testing in the field and also in the process lab, located in Kenosha, Wisconsin.

## R&D and Consulting Services

Available for any centrifugal separation process, our fully staffed lab performs services as needed.

- Lab centrifuge for decanter type centrifuge sampling
- Process engineer team available for testing and specification write-ups to insure correct machine sizing and type
- Process optimization consulting available for all decanter centrifuge brands



## Why Choose Centrisys?

### Installation and Start-Up *for All Brands\*\**

Offering on-site assistance with plant personnel ensures they are comfortable with running the equipment and have a thorough mechanical understanding of the centrifuge. Topics include, but are not limited to:

- Testing, set-up and process optimization
- Polymer dosing
- Checking lubrication system
- Adjusting belt tension
- Diagnosing alarms
- Adjusting speed sensors
- Diagnosing differential speed
- Preventive maintenance tips



### Centrifuge and Process Training *for All Brands\*\**

On-site or at one of our service facilities, we offer basic and advanced training for mechanics, operators and engineers. Topics include, but are not limited to:

- Centrifuge operation
- Maintenance and troubleshooting
- Polymer and process optimization
- Centrifuge terminology and calculations
- Bearing types, uses, and failures
- Pump repairs
- Purge systems setup and testing
- Diagnosing vibrations, alarms and noise

*\*\*Call or email if you have installation or training specific topics needed for your team.*

### Service ■ Repair ■ Optimization *for All Brands*

Our 30 year foundation in service, combined with our comprehensive knowledge of all brands of decanter centrifuges, makes us the most experienced in the industry. We offer a full range of services from preventive maintenance, rebuild and retrofit of decanter centrifuges.

### On-Site Field Service *for All Brands*

Centrisys has a field service team of experienced, fully trained centrifuge technicians nationwide and globally, available 24/7.



### Service Agreements *for All Brands\*\*\**

A variety of flexible and competitive service and maintenance agreements are available. We offer several different plans and options and all agreements are customized to fit your needs.

*\*\*\*Service contracts offer discounted parts and labor.*

### Rotating Assembly and Scroll Exchange Programs

Our rotating assembly and scroll exchange program for Centrisys centrifuges allows for the fastest service to get your centrifuge back up and running.

### Parts *for All Brands*

Along with our own Centrisys OEM parts, we carry the highest quality parts for all brands of centrifuges. Our 20,000 sq. ft. parts distribution center offers the largest in-stock selection of centrifuge parts. Preventative maintenance, critical wear and ancillary parts are all readily available for same day shipment.

- **Parts Warranty:** All parts and components are covered under the Centrisys standard warranty terms and conditions
- **Re-Engineered Aftermarket Parts:** We guarantee, high-quality aftermarket parts for all decanter centrifuge brands. Parts are reverse-engineered to work out any weaknesses based on the wear patterns from the original OEM part. This ultimately creates a stronger part for optimized performance.



## Questions about Centrisys technologies?

**Corporate** 9586 58th Place | Kenosha, WI 53144 USA P +1 (262) 654-6006 E [info@centrisys.com](mailto:info@centrisys.com)  
**Global Presence** North America | South America | Europe | Middle East | China



ISO 9001:2015

## Advancing Environmental Innovation

### Who is CNP?

CNP stands for **C**arbon, **N**itrogen and **P**hosphorus. CNP - Technology Water and Biosolids Corporation designs and supplies nutrient recovery and biosolids treatment optimization systems. Led by an experienced team of wastewater industry veterans, CNP continues to pioneer innovative wastewater systems solutions that positively impact the operational costs of treatment plants worldwide. CNP's key technologies are AirPrex® and CalPrex®, phosphorus recovery technologies, and PONDUS, a Thermo-Chemical Hydrolysis Process (TCHP). CNP is a division of Centrisys Corporation and headquartered in Kenosha, Wis.

#### CalPrex®

The CalPrex process harnesses the acidogenic bacteria power to acidify bio-P sludge. Over 60% of phosphorus solubilizes in the acid phase digestion process. Dewatering acidogenically digested sludge isolates the dissolved phosphorus (orthophosphates) in the centrate. The centrate is sent to the CalPrex reactor, where orthophosphates are precipitated by calcium hydroxide. By maintaining a pH solution of 6.5 or below, phosphorus is recovered as brushite ( $\text{CaHPO}_4 \cdot 2\text{H}_2\text{O}$ ), a market-ready, high-quality fertilizer.

#### AirPrex®

AirPrex turns struvite into an opportunity for resource recovery and installs between the anaerobic digester and the dewatering equipment. AirPrex converts the orthophosphates in digested sludge to struvite ( $\text{MgNH}_4\text{PO}_4 \cdot 6\text{H}_2\text{O}$ ) by air stripping  $\text{CO}_2$  and adding magnesium chloride. Struvite is another market-ready fertilizer. AirPrex reduces the phosphorus recirculation by 90%.



#### CalPrex® + AirPrex®

The combination of CalPrex + AirPrex captures 50%+ phosphorus entering treatment plants, with a minimal addition of chemicals.

#### PONDUS (TCHP)

CNP has exclusive North American distributorship of PONDUS, a Thermo-Chemical Hydrolysis Process (TCHP). The process also reduces sludge volume and polymer consumption. Steam is not necessary, making PONDUS a cost effective solution for treatment plants ranging in size from 10 mgd to 160 mgd. A treatment plant using PONDUS can expect a 25-30% increase in methane production compared to a plant not using PONDUS' innovative technology.

#### Passavant® Variable Inlet System hydrograv® adapt

In 2018, Centrisys/CNP became the exclusive North American distributor of Passavant® Variable Inlet System hydrograv® adapt, an inlet system that adjusts loading to fluctuations in a secondary clarifier.

**Corporate** 9586 58th Place | Kenosha, WI 53144 USA  
**P** +1 (262) 654-6006 **E** info@cnp-tec.us

**Global Presence** North America | South America | Europe | Middle East | China

### CNP at a Glance

#### Installations

- 2018 – First North American AirPrex installations complete by the end of the year: Liverpool WWTP in Medina, Ohio and Little Patuxent Water Reclamation Plant - Howard County in Savage, Maryland
- March 2017 – CNP acquires CalPrex global licensing and distribution
- 2014 – First North American PONDUS installation at Kenosha WTP in Kenosha, Wis.
- 10 AirPrex global installations
- 6 PONDUS global installations

#### Awards

- 2018 Utility of the Future Today Recognition Program for the Kenosha WWTP Optimization Project (PONDUS)
- 2017 W&WD Top Project for the Kenosha WWTP Optimization Project
- 2017 ACEC Grand Award for the Kenosha WTP Energy Optimized Resource Recovery Project (PONDUS)
- 2016 U.S. Environmental Protection Agency (EPA) Nutrient Recycling Challenge Award (AirPrex)
- 2015 Green Tec Award (AirPrex)

#### Company Leadership

- Gerhard Forstner, *CNP North America President*
- Michael Kopper, *C.E.O. and Founder of Centrisys*
- Menachem Tabanpour, *V.P. of Business Development*
- Zhongtian (John) Li, *Ph.D., Technical Manager*
- Joseph Hughes, *P.E., Project Manager*
- Patrick Mullen, *Project Manager*

#### Facilities & Locations

- CNP North America - Kenosha, Wisconsin
- CNP Cycles - Hanau, Germany

# Learn More from Our Industry Experts

**Michael Kopper**  
Centrisys President/C.E.O | Centrifuge Specialist



Kopper is a centrifuge expert with over 45 years of experience in sludge dewatering and thickening. His innovative way with problem-solving resulted in designing the smallest, CS6-4, and the largest, CS44-4, dewatering centrifuges this year. Not one to take the traditional route to most of what he does, Kopper is happy to discuss

how he believes an unconventional approach to building the Centrisys/CNP team will lead to its success.

**Gerhard Forstner**  
CNP President | Nutrient Recovery Specialist



With a thorough understanding of biosolids treatment systems, Forstner is instrumental in positioning Centrisys/CNP as a leader in nutrient recovery and sludge optimization solutions. The first two U.S. AirPrex installations are underway in Medina, Ohio and Savage, Maryland. Forstner can discuss the benefits of using

AirPrex to remove struvite and also how the process improves plant treatment efficiencies.

**Menachem Tabanpour**  
V.P. of Business Development | CalPrex Specialist



Tabanpour's nutrient recovery experience dates back to 2002, when he began research on controlled struvite crystallization at the University of Wisconsin-Madison. Tabanpour will be on hand to discuss the results and findings from the WRF partnership research CalPrex pilot that is running from September to November in

Madison, WI, reducing total phosphorus up to 42%.

**Hiroko Yoshida, Ph.D.**  
R&D Director | 2018 Young Professional Recipient



Yoshida has worked on the THK sludge thickener launch, analyzed sludge in the process lab and now leads the R&D team. Working her way up the ranks allows Yoshida to be a key developer for customized dewatering solutions with emerging, innovative technology. As Yoshida says "It's easy to have a dewatering process detailed on paper, but you need to get your hands dirty to make it a reality."

**AirPrex**  
Oct 3 @ 3:30 p.m.

**Dr. Andreas Dünnebeil, Ph.D.**  
Mechanical Engineer | PONDUS Inventor



Dr. Dünnebeil's industrial and municipal wastewater treatment career focuses on sludge treatment. In 2005, he founded PONDUS® Verfahrenstechnik GmbH and installed PONDUS in six German plants. In 2014, he began the partnership with Centrisys/CNP, who has exclusive U.S. distributorship. In 2015, Kenosha Water Utility, Wisconsin was

the first U.S. installation and has won numerous awards and recognition for the technology. He earned his doctorate from the Technical University of Berlin.

**Dr. Martin Armbruster, Ph.D.**  
Managing Director & Founder of hydrograv GmbH | hydrograv adapt Inventor



**PRESENTER**

**hydrograv adapt**  
Oct 3 @ 1:50 p.m.

Dr. Armbruster's expertise in the field of clarifier CFD simulation includes optimization and practical engineering for more than 1,000 clarifiers in 200+ treatment plants worldwide. His experience in improving hydraulic efficiency of water management systems is based on 500+ hydrograv® with CFD simulations installations. He studied civil engineering at the Karlsruhe Institute of Technology.

**Andre Adams**  
Mechanical Engineer | THK Product Director



Adams is our "go-to" for the THK sludge thickening technology. Find out why both municipal and industrial plants are realizing the benefits of using a thickener that is engineered specifically for sludge thickening; the THK not a modified dewatering centrifuge. Learn how it lowers life-cycle costs using little to no polymer and uses up to 50% less power compared to modified centrifuges.

**Zhongtian Li, Ph.D.**  
Technical Manager | AirPrex & PONDUS Specialist



**PRESENTER**

**PONDUS**  
Oct 2 @ 4:00 p.m.

Li joined CNP in 2016 and is the lead developer of pilot test and project commissioning procedures for phosphorous recovery and Thermo-Chemical Hydrolysis Process initiatives in North America. He holds an MBA from the University of Nebraska-Lincoln and a Ph.D. from UCLA in Civil Engineering.



## Questions about Centrisys/CNP technologies?

**Corporate** 9586 58th Place | Kenosha, WI 53144 USA **P** +1 (262) 654-6006 **E** [info@centrisys.com](mailto:info@centrisys.com)  
**Global Presence** North America | South America | Europe | Middle East | China



ISO 9001:2015

© CENTRISYS CORPORATION | No part of this copyrighted work may be reproduced, modified or distributed in any form or by any means, or stored on any database or retrieval system, without the prior written permission of CENTRISYS CORPORATION or its affiliates. Any such unauthorized use for any purpose is a violation of the relevant copyright laws.

BCWW2018v1EN



Just the Facts:

# Why New York City Chose Centrisys

## Rigorous analysis showed a clear winner for one of the largest dewatering upgrade projects in the country

The Wards Island Wastewater Treatment Plant is the second largest of the 14 wastewater treatment facilities in New York City, serving about 1 million people with an average dry-weather flow capacity of 275 MGD.

As part of a series of upgrades to improve pollution control and treatment efficiency, the NYC Department of Environmental Protection set out to evaluate dewatering centrifuge technology to replace the existing centrifuges at Wards Island. After rigorous bidding, NYC choose to install (16) CS26-4 Centrisys decanter centrifuge.

## On balance of objective criteria, Centrisys' system deemed superior

Using a matrix incorporating an array of weighted criteria established to seek the greatest overall value, CDM Smith ranked the products and manufacturers by their total scores.

Despite being the second highest in capital cost, the Centrisys CS26-4 came out on top due to facts including:

- Highest G-volume of installed centrifuges
- Highest torque capacity
- Lowest measured power consumption\*
- Second-lowest operating costs
- Most installations worldwide for machines of this size and capacity
- The only centrifuge using an advanced hydraulic scroll drive instead of a gearbox
- Minimal structural and mechanical modifications needed for installation

\*See chart on back. Bid #5 power consumption was a calculation.

## Five Competing Centrifuge Systems of Similar Capacity Considered

The DEP enlisted one of the world's foremost water quality consulting firms for a feasibility study comparing the following models:

- Alfa Laval G2-115
- Andritz CP4-1.2 (a retrofit using the same frame)
- Andritz D6LX
- Westfalia CF700
- Centrisys CS26-4

All these models were mid-feed or counter-current designs using AC variable-frequency drives (VFDs) for the main drive motors. All evaluated centrifuges, with the exception of Centrisys, used various gear drive configurations – ranging from two- to four-stage planetary or cyclo-gear reducers. The Centrisys CS26-4 operates using its standard back drive system – the Viscotherm hydraulic scroll drive based on Rotodiff® technology, controlled through a VFD.



## Better than Specification Performance

Performance testing for the Wards Island CS26-4 centrifuge installation demonstrated **better than specification performance results**.

- 50% power reduction compared to old centrifuges
- 25% higher throughput compared to old centrifuges
- 17% lower polymer consumption than specification
- 1% drier cake than specified and guaranteed
- 99% capture at 270 gpm (4% higher than specified and guaranteed)



### The Centrisys Advantage: Easy Integration

The Centrisys engineering team integrated a centrifuge stand, diverter gate and interconnecting pipework into the plant design. These design elements created a “drop in place” centrifuge system, allowing for easy integration with only few minor modifications to the existing floor plan.

### What's Next?

- **Hunts Point:** (16) CS26-4 scheduled for shipping January 2018, completing January 2019
- **26th Ward:** (16) CS26-4 scheduled for shipping June 2018, completing January 2020

### Wards Island Performance Test - July 12-13, 2017

The data acquired below is from the Wards Island Process Control Laboratory. The New York DEP randomly selected Centrisys CS26-4 decanter centrifuges #5703 and #5705, from the 10 installed centrifuges at the time, to conduct the 48-hour performance test. The gpm was kept around 250, but each unit demonstrated better than specification performance while running at 270 gpm for two hours. This was to meet the solids load of 2,210 lb/hr as the feed solids was below 1.6%, the average feed solids, during the two hours.

	Flow Rate [GPM]	Cake Solids [% TS]	Polymer Dose [lb/dry ton]	Capture Rate [% w/w]
<b>Bid Specs</b>	<b>250</b>	<b>26%</b>	<b>36</b>	<b>95%</b>
<b>Unit 5703</b>	<b>252.5</b>	<b>26.7%</b>	<b>29.8</b>	<b>99%</b>
<b>Unit 5705</b>	<b>252.5</b>	<b>27.1%</b>	<b>28.2</b>	<b>99%</b>

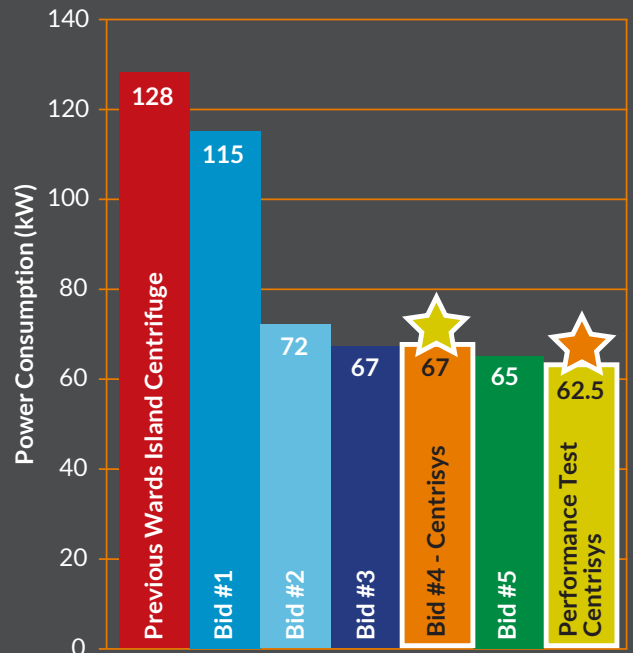

## Dewatering Specs

### Centrisys CS26-4 Centrifuge

### Wards Island

- Flow Rate** - 200-400 GPM
- G-Force** - 3,000
- Torque** - 30,000 Nm
- Standard Main Motor HP** - 100 HP
- Scroll HP** - 25 HP
- Beach Angle** - 15 degrees
- Bowl Diameter** - 26 inches
- Bowl Cylinder Length** - 90 inches

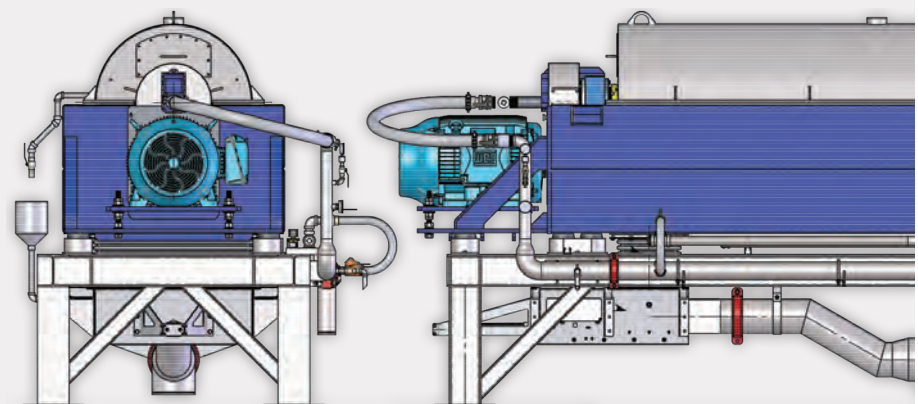

## Questions about Centrisys technologies?

**Corporate** 9586 58th Place | Kenosha, WI 53144 USA P +1 (262) 654-6006 E info@centrisys.com  
**Global Presence** North America | South America | Europe | Middle East | China



ISO 9001:2015



# The Right Solution, the Fastest Payback

## Centrisys Dewatering Centrifuge

In 1987, Centrisys designed and built its first centrifuge around what was learned in the field by servicing competitor's equipment in both municipal and industrial applications. Thirty years later, the Centrisys engineering team continues to benefit from problem-solving, learning what does and does not work in the real world and takes that knowledge to continue Centrisys' lifelong commitment to brand excellence. By providing the most efficient, robust decanter centrifuges, Centrisys gives our customers the results they need.

- Increased solids handling
- Reduced polymer consumption
- Higher flow rates
- Lower operating and maintenance costs
- Reduced disposal costs
- Lowest energy consumption
- Continuous operation
- Lowest installed horsepower
- Driest cake

Centrisys centrifuges can be customized for unique application requirements. For further information about customized centrifuges, contact your Centrisys sales representative.



## Why Choose Centrisys?

- 1 U.S.A. Engineered and Manufactured:** A Centrisys centrifuge is designed, engineered and built with pride at our corporate headquarters in Kenosha, Wisconsin
- 2 Centrisys-Viscotherm Scroll Drive:** The most efficient in the industry with a simplified design; highest torque to weight ratio with the best process control
- 3 Highest Quality:** All structural bowl components are centrifugally cast or forged for ultimate integrity and strength
- 4 Advanced Wear Protection:** Progressive wear protection prolongs the life of your centrifuge, increases uptime, optimizes performance and reduces service and maintenance costs
- 5 Scroll Design and Development:** Axial flow design promotes settling of even the finest solids, improves the recovery rate and reduces polymer consumption
- 6 Centrifuge Energy Recovery System (CERS):** The centrifuge can restart anytime during a shutdown period (on the fly or standstill) and prevents a costly dis-mantle to free-up a blocked centrifuge



Dewatering Solutions: USA Built, Sold & Serviced Around the World

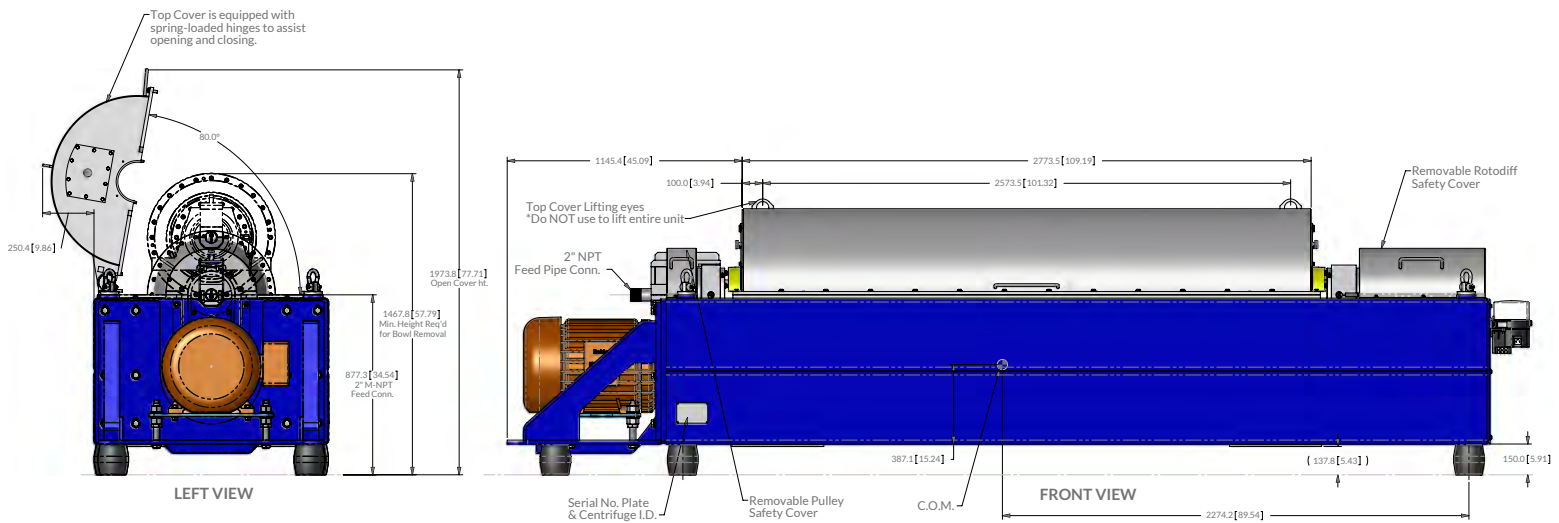

Dewatering Decanter Centrifuges CS Series

	CS6-4	CS10-4	CS14-4	CS18-4	CS18-4HC	CS21-4	CS21-4HC	CS26-4EV	CS26-4	CS30-4	CS44-4
Phase	2/3	2/3	2/3	2/3	2/3	2/3	2/3	2/3	2/3	2/3	2
Feed Capacity* gpm (m <sup>3</sup> h)	2-10 (0.5-2)	5-35 (1-8)	20-60 (5-14)	50-100 (11-23)	75-125 (17-29)	100-175 (23-40)	150-225 (34-51)	150-320 (34-73)	200-400 (45-90)	300-700 (68-159)	500-1,000 (114-227)
Weight lbs (kgs)	700 (318)	2,000 (910)	3,800 (1,725)	6,500 (2,950)	8,200 (3,720)	8,500 (3,860)	10,000 (4,550)	16,500 (7,490)	18,500 (8,400)	30,000 (13,600)	50,000 (22,680)
Total Installed Power HP (kW)	8 (6)	20 (15)	40 (30)	50 (38)	60 (45)	75 (56)	90 (68)	140 (105)	165 (123)	275 (205)	450 (336)
Avail. Shallow Pool/Angle	Yes	Yes	Yes	Yes	Yes	Yes	Yes	Yes	Yes	Yes	Yes
Auto Lube System	Yes	Yes	Yes	Yes	Yes	Yes	Yes	Yes	Yes	Yes	Yes
L x W x H in (m)	75 x 21 x 28 (1.9x0.5x0.7)	89 x 44 x 27 (2.3 x 1.1 x 0.7)	122 x 34 x 31 (3.1x0.9x0.8)	151 x 44 x 41 (3.8 x 1.1 x 1)	175 x 44 x 47 (4.5x1.1x1.2)	175 x 44 x 47 (4.5x1.1x1.2)	190 x 45 x 53 (4.8x1.2x1.4)	210 x 56 x 62 (5.3x1.4x1.6)	225 x 56 x 62 (5.7x1.4x1.6)	258 x 74 x 75 (6.6x1.9x1.9)	248x122x70 (5.2x3.1x1.8)
Cake Dryness	Up to 40% depending on process type and condition										

\*Feed capacity based on municipal applications. Actual throughput based on sludge characteristics. Centrisys reserves the right to change specs without prior notification.

Questions about Centrisys technologies?

**Corporate** 9586 58th Place | Kenosha, WI 53144 USA P +1 (262) 654-6006 E info@centrisys.com  
**Global Presence** North America | South America | Europe | Middle East | China



ISO 9001:2015



# The Most Efficient Solution to Thicken Sludge

## Centrisys Sludge Thickener

The Centrisys Sludge Thickener (THK Series) is specifically engineered to achieve high-performance thickening of biosolids. The non-conical design results in greater G-volume, allowing for the highest capacity of flow to the centrifuge. The THK improves upon existing technologies using fundamental principles of a 1) Centrifuge - 3,000 Gs, 2) Rotary Drum Thickener - fully enclosed and small footprint, 3) Dissolved Air Flotation (DAFT) - air injection. The patented Hydro-Pneumatic design has proven that NO polymer is required under normal conditions (150 SVI).

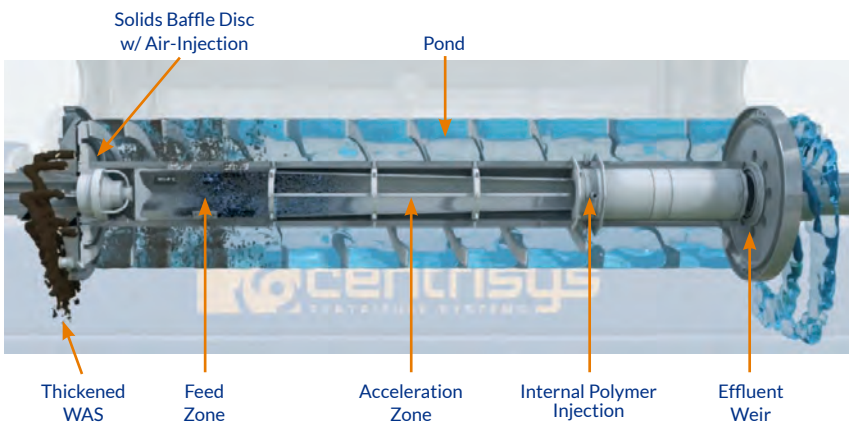

- No-Conical = greater comparative capacity
- Proprietary hydro-pneumatic control of cake solids
- Independent control of liquids and solids weir
- Greater G-volume
- Proprietary internal polymer injection system (optional)
- Highest grade materials of construction
- Proprietary tungsten carbide wear plows for grit and trash

## Typical Applications

- Primary sludge
- Secondary (waste activated) sludge
- Oxidation ditch sludge
- Digested sludge
- MBR (membrane bioreactor) sludge
- Dilute pulp and paper waste prior to dewatering
- Concentration of food processing waste
- Concentration of algae
- Concentration of yeast

## Features

- Proven no polymer required under normal conditions (150 SVI)
- Smallest and most efficient footprint for given flow rates compared to gravity belt and rotary drum thickening technologies
- Contained vapor system
- Expected ROI of 2.5 years due to polymer savings alone
- Reduced operating and maintenance costs
- 50% less power consumption compared to standard dewatering centrifuges
- Reduced installation costs by 35-50% (\$/gpm)
- Simple to operate with minimal operator attention



**Thickening Solutions: USA Built, Sold & Serviced Around the World**



Sludge Thickener THK Series								
	THK100		THK200		THK350		THK600	
	Maximum	Average	Maximum	Average	Maximum	Average	Maximum	Average
Feed Flow Rate w/o Polymer* gpm	60	45	180	125	320	265	765	640
Feed Flow Rate w/ Polymer* gpm	150	105	250	200	500	425	1,100	800
Approx. Bowl Diameter in (m)	14 (0.36)		18 (0.45)		21 (0.53)		26 (0.66)	
Total Static Weight - Empty lbs (kg)	3350 (1,520)		5,000 (2,950)		10,800 (4,900)		27,000 (12,250)	
Standard Main Drive HP	25		50		75		150	
Standard Scroll Drive HP	10		10		15		25	
Standard Total Installed HP	35		60		90		175	
G-volume Capacity at 3,000 G gal	80,000		160,000		332,000		718,000	

Sludge Thickener THK Series Performance		Waste Activated Sludge (WAS)	WAS/Primary Blend
No Polymer Specific Power** kW/gpm	Minimum	0.07	0.08
	Maximum	0.18	0.19
	Average	0.12	0.15
Polymer Specific Power** kW/gpm	Minimum	0.05	0.05
	Maximum	0.15	0.18
	Average	0.08	0.10
Average Solids Recovery % wt./wt.	w/o Polymer	93	90
	w/ Polymer	99	97
Average Cake Solids % Total Solids	w/o Polymer	4 to 7	
	w/ Polymer	5 to 10	

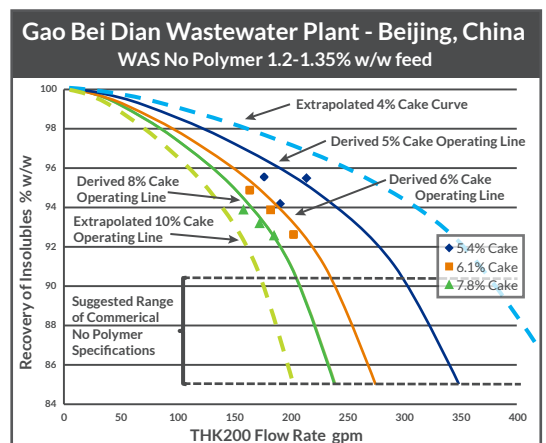

\*Values are approximate for Influent Solids of 0.5% to 1.5% WAS. \*\*Specific power estimations are for normal flows. Contact Centrisys for project-specific calculations.

**Questions about Centrisys technologies?**

**Corporate** 9586 58th Place | Kenosha, WI 53144 USA P +1 (262) 654-6006 E info@centrisys.com  
**Global Presence** North America | South America | Europe | Middle East | China



ISO 9001:2015



# CSI Program

## 40+ Point Inspection

**Prevent Failures. Reduce Repair Costs.**  
**Embrace Reliability. No Surprises.**

Centrifuge inspections shouldn't be viewed as a burden. Knowing the condition of your centrifuge and its components allows for reduced repair costs, more uptime, proactive forecasting for future repairs, as well as, maintaining a safe environment for your plant operators.



**What is the CSI Program?** The Centrisys Service Inspection (CSI) Program is a one-time, one day, on-site centrifuge inspection that covers examining and reporting back to you the condition of 40+ critical areas on your decanter centrifuge.



**Why 40+ Points?** After 30 years of servicing decanter centrifuges, the Centrisys service team has the experience to identify the areas of a centrifuge that are critical for performance, reliability, safety and operational budget forecasting.



**What does the comprehensive inspection report\* cover?** The report has detailed sections documenting the technician's findings during the one day inspection. The report includes photos, notes and recommendations along with a color key code to quickly view the status of the 40+ points:

**RED = critical** | **YELLOW = caution** | **GREEN = good**

*\*Contact your Centrisys Regional Sales Manager for a sample report.*



**Is the CSI Program only for Centrisys centrifuges?** Centrisys has over 30 years of experience servicing all brands and models of decanter centrifuges. The CSI Program is available for all decanter centrifuge makes and models.



**CSI+ Package\*\*** is a 4-6 hour on-site general maintenance add-on to the Centrisys CSI Program.

**How it works:** Once you sign-on for the CSI Program, you can add the CSI+ General Maintenance Package. With a Centrisys technician already on-site, it may make sense to take that extra step to assure your centrifuge general maintenance is up to date.

What maintenance is performed?

- Drain and replace oil from the hydraulic pump
- Clean the hydraulic tank
- Change the hydraulic oil and filters
- Replace belts (if needed)
- Replace the suction strainer (if needed)
- Informal operator training on centrifuge operation, general maintenance and safety standards

*\*\*Labor and parts pricing are based on Centrisys centrifuges. Other centrifuge brands parts pricing & availability are subject to change.*



### What is 365 Support\*\*\*

Once you sign the CSI Program, you are automatically enrolled in 365 Support. The program includes:

- Unlimited phone support with senior service managers
- 24/7 emergency call line
- 10% discount on labor
- 10% discount on Centrisys parts
- 10% discount on rental equipment
- 1 year warranty on parts
- Priority shipping on parts
- Preferential scheduling of repairs and upgrades
- Customized maintenance plan for operation conditions of your centrifuge
- Centrisys newsletter

*\*\*\*365 Support is an annual plan. To renew the yearly plan, e-mail [servicedept@centrisys.com](mailto:servicedept@centrisys.com) or contact your Centrisys Regional Sales Manager at (262) 654-6006.*

### Available Support Upgrades

- Preventative maintenance agreement
- Extended warranties
- Formal operator training (1 day)
- Advanced process optimization with recommendations

**Centrifuge downtime is preventable by performing regular maintenance. Contact Centrisys.**

### Questions

+1 (262) 654-6006

### Service

[servicedept@centrisys.com](mailto:servicedept@centrisys.com)

### Parts

[parts@centrisys.com](mailto:parts@centrisys.com)





## The Importance of Inspection and Maintenance

Having a state-of-the-art decanter centrifuge is no guarantee of optimum performance and efficient processes. It is just as important to have your centrifuge regularly inspected and maintained as it is to have it installed correctly.



### Suggested Plant Maintenance Guidelines\*

Daily Maintenance	
Fasteners & Guards	Visually check external fasteners for looseness and guards for cracking
Discharge Hoppers & Piping	Check for leaks
Operations Log	Fill out normal operations log to record temperature, erratic vibration, differential speed, torque and flow rates
Lubricator	Check level visually
Control Panel	Check for faults and verify normal readings
Noise & Vibration	Observe noise and vibration levels on panel
Weekly Maintenance	
Grease Internal Bearings	See your Operations & Maintenance Manual
Check Belt Tension	
Check Lubricant & Oil Levels	
Monthly Maintenance	
Inspection for Wear	Open top cover, remove safety covers and inspect rotor and housing for wear.
Monitor Vibration	Verify vibration levels are at or below normal operating levels on the panel display
Wiring, Electrical Cords, Etc.	Check for wear or damage. Replace if necessary.
Discharge Areas	Check solids and liquid discharge areas for wear and obstruction
Annual	
Function Check	Verify function of interlocks and system controls, check PLC battery

Bearings & Seals		Frequency
Main Bearings	Replace	15,000 hrs
Internal Bearings	Replace	15,000 hrs
Wear Components		
Feed Nozzles	Inspect for wear; replace worn nozzles if needed	At inspection
Discharge Nozzles	Inspect for wear; replace worn nozzles if needed	
Tiles	Inspect for wear; replace worn tiles if needed	
Feed Chamber Area	Inspect for wear; replace components if needed	
Internal Inspection of Rotor		
Remove Scroll	Inspect for wear and damaged components	15,000 hrs or 5 years maximum
Hydraulic System		
Oil & Filter Change	Change oil and filter	4,000 hrs or twice a year
Hydraulic Pump Unit	Inspect for leaks and damage to hoses	Monthly
Rotodiff Hydraulic Motor or Gearbox	Inspect and change bearings and seals	15,000 hrs
Balancing		
Bowl	Balance to specification	15,000 hrs
Scroll	Balance to specification	15,000 hrs

\*Guidelines for Centrisys municipal wastewater centrifuges. Industrial applications may vary.

## Questions about Centrisys technologies?

**Corporate** 9586 58th Place | Kenosha, WI 53144 USA P +1 (262) 654-6006 E info@centrisys.com  
**Global Presence** North America | South America | Europe | Middle East | China



ISO 9001:2015

### **Little Patuxent Water Reclamation Facility Upgrades System with AirPrex® for Sludge Optimization and P-Recovery**

**CNP – Technology Water and Biosolids**, a division of Centrisys Corporation in Kenosha, Wisconsin, recently supplied the Howard County Department of Public Works with the patented CNP AirPrex process. AirPrex, scheduled to be operational during the Q3 2018, will improve the current biosolids processing facility by sequestering phosphorous and preventing the formation of phosphorous scale known as struvite.

Howard County Department of Public Works engaged HDR to provide engineering design services for upgrades to the biosolids facilities at the Little Patuxent Water Reclamation Facility in Savage, Maryland. The Little Patuxent facility used dewatered cake lime stabilization for biosolids treatment. The changes to the biosolids processing included eliminating the lime system and replacing it with anaerobic digesters, centrate demmonification and associated solids screening, thickening, odor control and digester gas handling improvements.

After an extensive evaluation of phosphorous removal technologies, the design was based on AirPrex because of its demonstrated ability to prevent struvite precipitation in downstream processes, including piping and the solids dewatering equipment. The Little Patuxent facility uses decanter centrifuges for biosolids dewatering.

The AirPrex process is a patented phosphorus recovery technology owned by CNP. AirPrex reduces problematic struvite buildup in wastewater treatment plants improving overall plant efficiencies, including dewatering improvements resulting in significant operational cost savings for treatment plants.

AirPrex's flexibility was another factor in the design. The process either sequesters struvite, leaving it in the biosolids stream for land application on farm fields as fertilizer, or recovers struvite, separating it from the biosolids stream. Once separated, the struvite can be used as a beneficial slow-release fertilizer.

Howard County selected the Construction Manager at Risk (CMAR) delivery method for the construction of the upgrades and installation of AirPrex. Clark Construction, the CMAR contractor, negotiated with Kershner Environmental Technologies, the local CNP representative, on behalf of the county to procure AirPrex.

The Little Patuxent Water Reclamation Facility is a 29 MGD advanced wastewater treatment plant using enhanced nutrient removal processes to reduce nitrogen and phosphorous discharges to the Chesapeake Bay. The facility serves 56 percent of the county's 317,000 population.

*CNP – Technology Water and Biosolids designs and supplies nutrient recovery and biosolids treatment optimization systems. CNP's key technologies are: AirPrex® and CalPrex™, phosphorus recovery technologies, and PONDUS™, a Thermo-Chemical Hydrolysis Process (TCHP). CNP is a division of Centrisys Corporation. Centrisys Corporation is a U.S.A. manufacturer of dewatering centrifuges, sludge thickeners and complete dewatering systems for municipal and industrial wastewater. The company's focus is centrifuge equipment, including the award winning THK sludge thickener. Centrisys provides global service, repair and parts for all brands of centrifuges.*

**For more information, please contact:**

Centrisys/CNP

9586 58<sup>th</sup> Place

Kenosha, WI 53144

262-654-6006

Jessie Jones, Marketing Associate

Email: [Jessie.jones@centrisys.us](mailto:Jessie.jones@centrisys.us)

Website: [www.cnp-tec.com](http://www.cnp-tec.com)

## **The Water Research Foundation Launches Tailored Collaborative Research Demonstration of CalPrex™ High Efficiency Phosphorus Recovery**

**Centrisys/CNP**, located in Kenosha, Wisconsin, is collaboratively working with: Milwaukee Metropolitan Sewerage District (Milwaukee, Wisconsin), Metro Wastewater Reclamation District of Denver (Denver, Colorado), Madison Metropolitan Sewerage District (Madison, Wisconsin), Massachusetts Water Reclamation Authority (Boston, Massachusetts).

Together, they will perform a Tailored Collaborative Research (TCR), a program of The Water Research Foundation (WRF), to demonstrate the phosphorus removal and recovery potential of the CalPrex process at the Madison Metropolitan Sewerage District from September to November.

The TCR will collect high-quality data from the CalPrex process and allow the participating utilities to evaluate high-rate phosphorus recovery prior to anaerobic digestion and its positive effects on operations and maintenance. This will help the utilities better meet stringent biosolids regulations and simultaneously mitigate operations and maintenance issues related to phosphorus levels in sludge. A peer review of the findings will be conducted and the results will be disseminated to industry professionals through the WRF LIFT Link platform.

Phosphorus (P) removal and recovery is one of the hottest topics in the wastewater biosolids industry today. Tightening regulations for both land application and sale of biosolids have water reclamation professionals eager to evaluate technologies that remove nuisance P from biosolids in a cost effective and sustainable manner.

*CNP – Technology Water and Biosolids designs and supplies nutrient recovery and biosolids treatment optimization systems. CNP's key technologies are: AirPrex® and CalPrex™, phosphorus recovery technologies, and PONDUS™, a Thermo-Chemical Hydrolysis Process (TCHP). CNP is a division of Centrisys Corporation. Centrisys Corporation is a U.S.A. manufacturer of dewatering centrifuges, sludge thickeners and complete dewatering systems for municipal and industrial wastewater. The company's focus is centrifuge equipment, including the award winning THK sludge thickener. Centrisys provides global service, repair and parts for all brands of centrifuges.*

**For more information, please contact:**

Centrisys/CNP  
9586 58<sup>th</sup> Place  
Kenosha, WI 53144  
262-654-6006  
Jessie Jones, Marketing Associate  
Email: [Jessie.jones@centrisys.us](mailto:Jessie.jones@centrisys.us)  
Website: [www.cnp-tec.com](http://www.cnp-tec.com)



## Kenosha Water Utility Energy Optimization Resource Recovery Project

“ While the technologies each individually bring value, it is their holistic approach, as well as the collaboration of partners involved, that make this project special. The key for this successful initiative is trust among partners – Kenosha Water Utility and Centrisys/CNP leaders – and trust from the City of Kenosha in these leaders to deliver. ”

**Ed St. Peter**  
Kenosha Water Utility General Manager

“ In one year’s time, the utility’s biosolids facilities were transformed to a state-of-the-art biosolids and energy showpiece. Complete cooperation of all project partners was integral to achieving success on this challenging project. ”

**Ed Nevers**  
Donohue & Associates Senior Vice President &  
Kenosha Water Utility Project Manager

### Project Roles

The Kenosha Water Utility elected to use a design-build approach due to the complex and varied technologies associated with this project. Centrisys/CNP Technology Water & Biosolids, a dewatering/thickening equipment manufacturer and nutrient recovery/sludge optimization provider, served as the design-build developer. Donohue & Associates served as the engineer of record.

### Project Summary

The Kenosha Water Utility completed the Energy Optimization Resource Recovery Project in 2015. The project reduced energy and solids handling costs by 20%, reduced dependence on fossil fuel energy by 40%, removed 10,000 tons annually from landfills and produced a Class A EQ biosolids product that produces the annual reuse of 500 tons of nitrogen and 250 tons of phosphorus.

The project delivered a **cost-effective and eco-friendly solution to biosolids handling, processing and disposal**. This design integrated equipment and processes never used in North America, while incorporating the technologies into existing buildings and a 1980s infrastructure. Goals included:

- Increase biogas generation from the sludge anaerobic digestion
- Generate electricity from the biogas to **produce over 500 kW of continuous power for the facility**
- Use electricity generated to offset peak energy pricing during high-demand periods
- Use electric and thermal energy to dry the biosolids and reduce the volume of biosolids cakes to 90%
- Eliminate the volume and cost of landfilled biosolids
- Produce high-quality biosolids that meet Class A biosolids criteria
- Recover and use waste heat as the main thermal energy supply for the facility

At the same time, the new process and individual technologies had to maintain the existing effluent quality and not increase ambient noise level, odor or particulates beyond the facility area.

### Project Goals

-  Increase Biogas Production
-  Generate Electricity from Biogas
-  Use Waste Heat as the Main Thermal Energy Supply
-  Achieve 90% Dry Cake and Class A Biosolids
-  Eliminate Landfill Disposal and Reuse Nutrients

### Questions about Centrisys/CNP technologies?

**Corporate** 9586 58th Place | Kenosha, WI 53144 USA P +1 (262) 654-6006 E info@centrisys.com  
**Global Presence** North America | South America | Europe | Middle East | China



ISO 9001:2015

CSKO2018v4EN

Discover more at [Centrisys.com](http://Centrisys.com)  
Discover more at [CNP-Tec.com](http://CNP-Tec.com)



## Original or Innovative Application of New or Existing Techniques

### Thermo-Chemical Hydrolysis Process (TCHP)

PONDUS uses caustic soda and heated water to break down waste-activated sludge and enhance biogas production. The thermal energy, required for the hydrolysis process, transfers and heats the digesters. This process breaks down the cell membranes of the thickened waste-activated sludge, releasing organic acids which are consumed quicker in the anaerobic digestion process.

Following installation, Kenosha achieved a 30% increase in biogas production. Minimal digester foaming has been experienced since the upgrade, attributed to PONDUS.

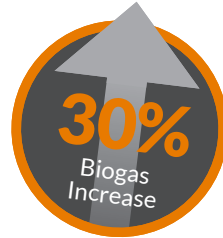

### Thickening Improvements

Centrisys THK200 thickens primary sludge to reduce the amount of water fed to the anaerobic digestion process. The benefit is significant, as it serves to:

- Increase digestion time
- Enhance digestion performance
- Enhance biogas production
- Reduce the amount of biogas required to heat the digesters

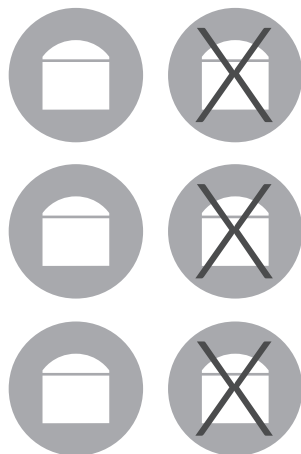

The THK200 doubled the solids concentration and cut in half the amount of water sent to the digestion process.

### Digester Improvements

Donohue designed the digester mixing system to perform at solids loading rates that far exceed conventional loading rates, almost double the recommended 10 States Standards and WDNR requirements. Pre-thickening the sludge with the THK200, along with the robust digester mixing system, allows the digestion process to perform with half of the original digester volume. Kenosha effectively operates with half the number of digesters in service, reducing from six to three.

### CHP Units

A pair of combined heat and power (CHP) cogeneration units are powered entirely by biogas, providing supplemental power to the plant. They also supply heat for the dryer, PONDUS, anaerobic digesters and central plant-heating loop. Each CHP unit is capable of producing 330 kW of electrical energy and 422 kW of thermal energy.

### Biogas Conditioning System

A biogas conditioning system was designed to reduce maintenance and increase the longevity of the CHP units.

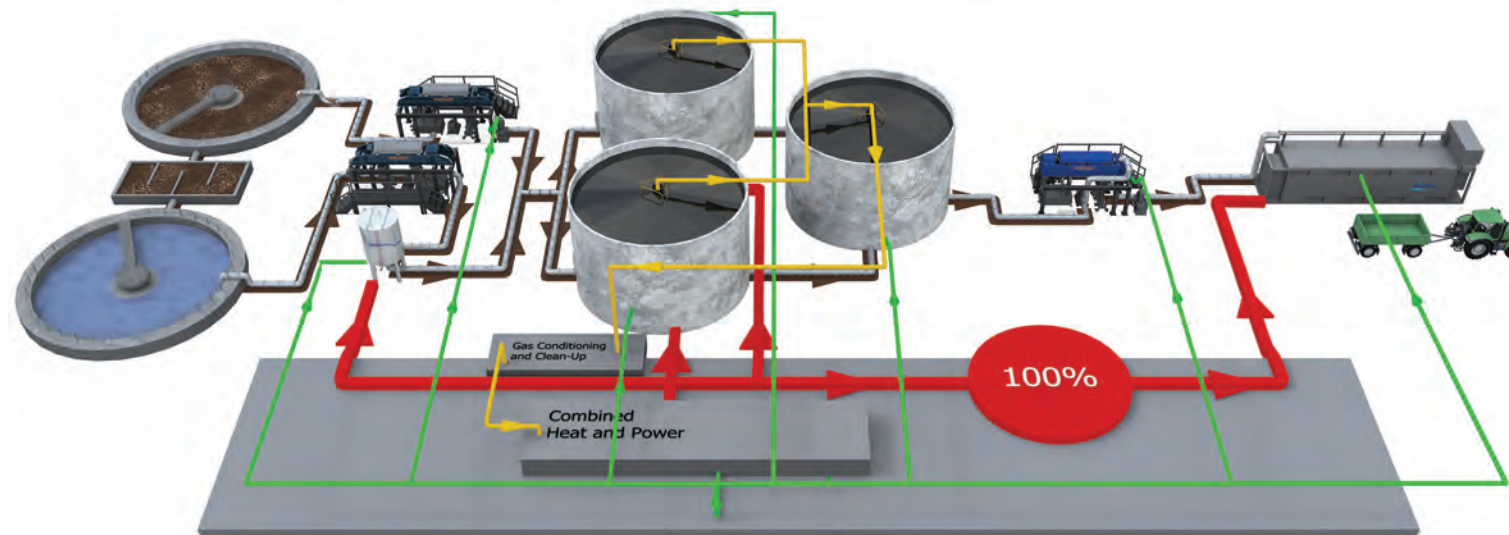

— Heat — Biogas — Electricity — Biosolids

### Sludge Dryer

SÜZLE KLEIN Compact-Dry is a dual belt, low temperature belt dryer using waste heat from the CHP units to evaporate water from the digested solids, reducing the biosolids volume by a third and converting the biosolids to Class A EQ. The dryer achieves all requirements for Class A, including temperature, duration and moisture content. Class A EQ biosolids can be used as a soil amendment, eliminating the high cost of landfill disposal.



### Pre-Energy Optimization Project Improvements



2009: Centrisys CS21-4HC dewatering centrifuge replaced three plate and frame presses, reducing the dewatering footprint, chemical usage (lime and ferric), disposal and operation costs. The ROI was 1.5 years.

2011: Centrisys THK200 for WAS replaced four DAFT units. The THK200 operated 24/7, used no polymer, achieved 5% TS cake and 95% capture. Kenosha also avoided \$100k in DAFT repairs. In 2015, for the Energy Optimization Project, the THK200 (WAS) was slightly modified to currently use a low polymer dosage to extend the operating range to 6-7% TS thickened solids for PONDUS.

### Exceeding Client/Owner Needs

The Kenosha Water Utility project represented a collaborative design-build partnership that brought together Donohue & Associates (engineers), Centrisys/CNP (project developer), contractors, subcontractors and Kenosha Water Utility officials to successfully complete the project on schedule and within budget. The design-build team was able to successfully design, build and operate the new facilities in 13 months. A typical approach normally takes two years or more. Today, the Kenosha Water Utility stands to save \$750,000 annually.



Original Total Budget Estimate = \$10,000,000  
(Includes \$2,500,000 for Existing Building Modifications)

Final Total Project Cost = \$9,312,957  
Final Process Cost = \$6,812,957

Scheduled Completion 11/30/15  
Actual Completion 11/30/15

### 2017 ACEC Grand Award Winner



Left to right: Ed St. Peter (Kenosha Water Utility), John Martin Antaramian (Mayor of Kenosha), Michael Kopper (Centrisys/CNP), G. John Ruffolo (4th District Kenosha Alderman), and Mike Gerbitz (Donohue & Associates)



## PONDUS Optimizes Your Sludge Treatment Process

More biogas, lower biosolids treatment and disposal costs, PONDUS TCHP is simple and effective without the use of steam.

- Reduce Viscosity of Thickened WAS up to **80%**
- Reduce Anaerobic Digestion Volume up to **50%**
- Improve Biosolids Dewatering up to **5%**
- Increase Biogas Production up to **30%**
- Reduce Polymer Consumption at Dewatering up to **20%**
- Reduce Digester Foaming

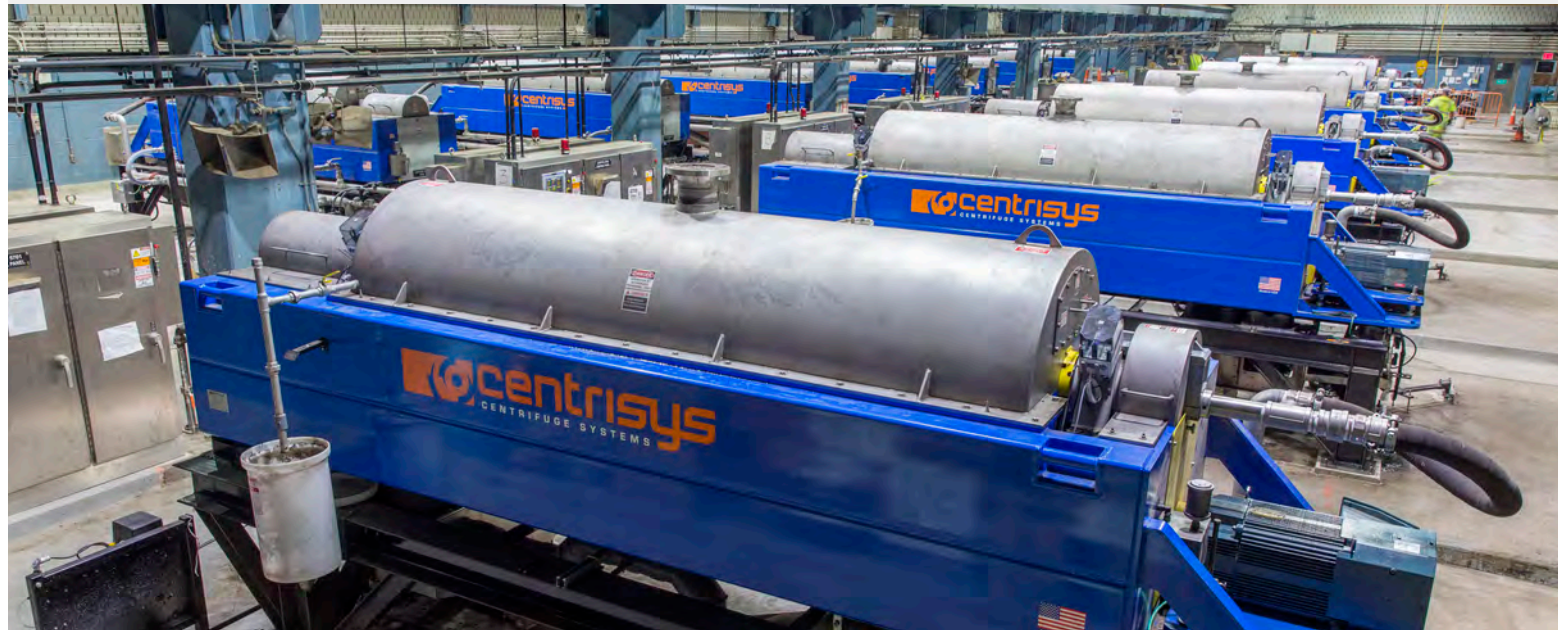

“ The upgrade has resulted in savings of \$1.1 million per year in power, polymer and biosolids disposal costs by improving dewatering operational efficiencies at the WI WWTP. In addition, the upgrade increased the dewatering capacity at Ward’s Island WWTP by 70%, which allows the New York City Department of Environmental Protection to decommission a dewatering facility at one of its other WWTPs. ”

**John Rogers**  
CDM Smith Associate Environmental Engineer

“ While the technologies each individually bring value, it is their holistic approach, as well as the collaboration of partners involved, that make this project special. The key for this successful initiative is trust among partners – Kenosha Water Utility and Centrisys/CNP leaders – and trust from the City of Kenosha in these leaders to deliver. ”

**Ed St. Peter**  
Kenosha Water Utility General Manager

# Do More with Less

Providing robust and cost effective solutions to meet the increasing demands for solids management



## Maximizing Efficiencies for Optimum Results

The Centrisys/CNP resource intensification portfolio is both an integrated process solution and/or an individual equipment approach to sludge and biosolids handling; leveraging **proven** technologies to provide viable alternatives to conventional treatment processes.

### + More

- Improve plant safety
- Improve plant efficiencies
- Increase energy efficiency
- Increase biogas production
- Increase nutrient recovery
- Improve nutrient quality
- Improve sludge dewaterability

### - Less

- Smaller footprint
- Reduce equipment size and needs
- Simplify the process steps
- Reduce chemicals and energy costs
- Lower cost of ownership
- Reduce operational and maintenance costs
- Reduce landfill and disposal costs

Biosolids management today is faced with challenges that are matched by unprecedented opportunities. A key source of these opportunities is the expanded view of wastewater and solids as renewable resources.

Source: EPA

## Questions about Centrisys/CNP technologies?

**Corporate** 9586 58th Place | Kenosha, WI 53144 USA P +1 (262) 654-6006 E info@centrisys.com  
**Global Presence** North America | South America | Europe | Middle East | China



ISO 9001:2015

CR12018v1.1EN

Discover more at [Centrisys.com](http://Centrisys.com)  
Discover more at [CNP-Tec.com](http://CNP-Tec.com)



# The Centrisys/CNP Portfolio Supports Global Sustainability

## 1 THK Series\* Primary Sludge Thickener

THK Series is designed specifically to achieve high performance thickening of biosolids. It is not a modified dewatering centrifuge.

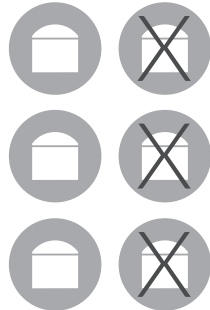

\*Also see information in #3.

- Proven no polymer performance
- No conical = greater comparative capacity
- Greater G-volume
- Independent control of liquids and solids weir
- **Digester volume needs are cut in half by doubling the feed concentration**
- Proprietary hydro-pneumatic control of cake solids

## 2 Passavant® hydrograv® adapt System Distributor for Aqseptence Group GmbH

Unlike fixed inlet structures, the Passavant hydrograv adapt System is a proven process that consistently and continuously adjusts to current loading. If the loads are low, the system adjusts the inlet elevation and opening height to a low position, introducing the mixed liquor below the sludge blanket. When the loads increase, it shifts to a higher elevation and opening height, **guaranteeing operation of the clarifiers under ideal hydraulic conditions and avoiding sludge overflow.**



## 3 THK Series\* Waste Activated Sludge (WAS) Thickener

THK Series sludge thickener is simple to operate with minimal operator attention and has the **lowest total cost of ownership** in the industry.



\*Also see information in #1.

- 50% less power consumption (compared to standard dewatering centrifuges)
- **Proven no polymer required**
- Enclosed unit reducing odors and gases
- Hygienic operation and safe for operators
- Smallest and most efficient footprint
- Reduce installation costs by 35-50% (\$/gpm)

## 4 PONDUS™ Thermo-Chemical Hydrolysis Process (TCHP)

PONDUS, an alkaline process, uses low grade heat (160 °F to 180 °F) and sodium hydroxide for sludge hydrolysis.

- No heat exchangers needed to cool sludge
- No steam required
- Minimal equipment needed: high-efficiency heat exchanger, progressive cavity pumps and a reactor operating under atmospheric pressure
- **Increase biogas production up to 30%**
- Reduce viscosity of thickened WAS up to 80%
- Reduce polymer consumption at dewatering up to 20%

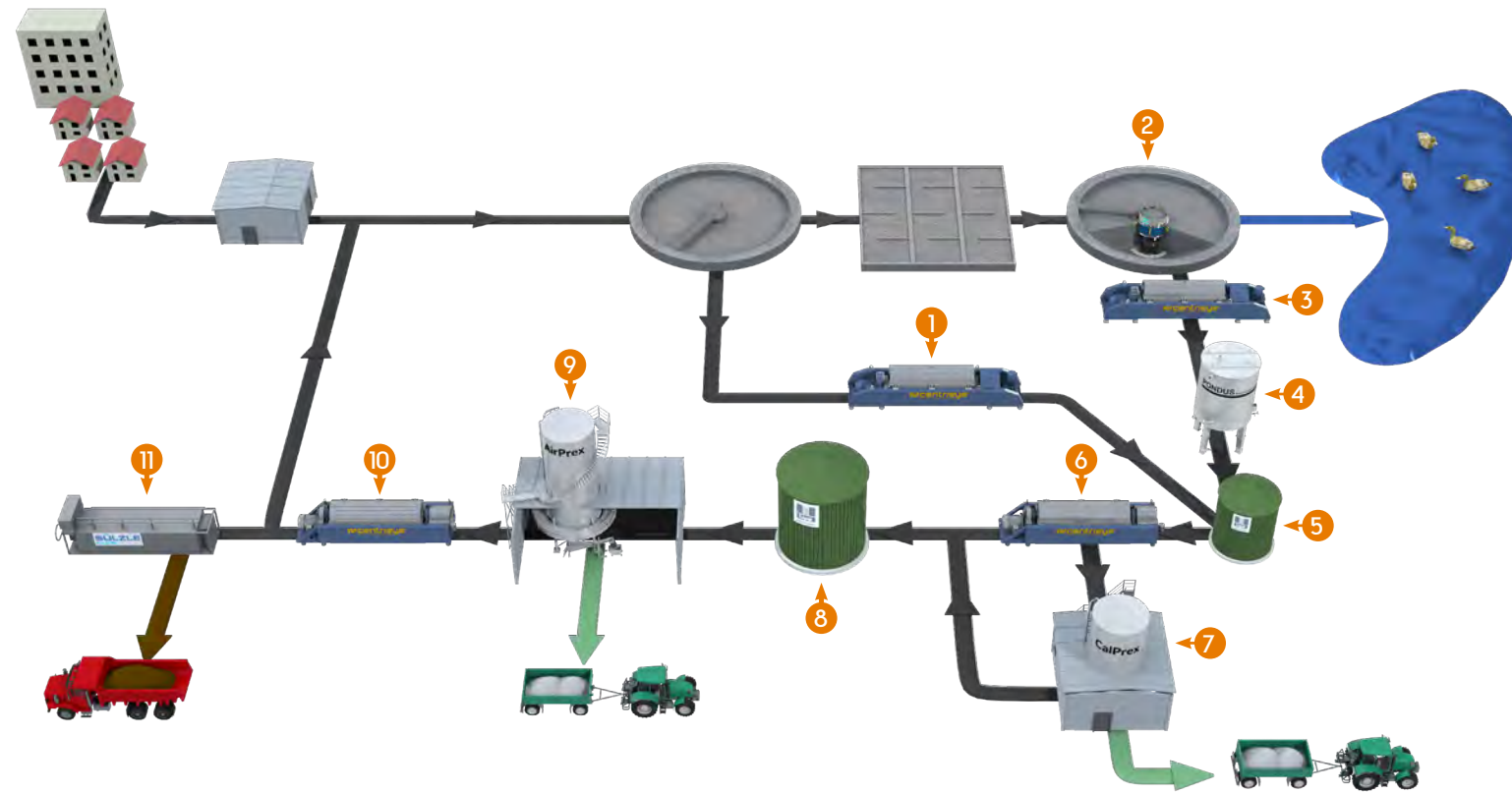
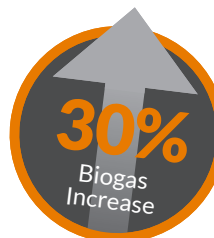

## 5 Liquid Container (Fermentation Tank) Distributor for LIPP America Tank Systems

Liquid Containers are for the storage and treatment of water and wastewater treatment liquids.

- 10,000 to 2,600,000 gallons
- Long operation life
- Flexible sizing, material and equipment
- **Quick assembly with the double-seam system**
- Corrosion resistance with the "Verinox" stainless steel interior lining system

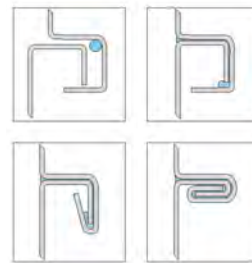

## 6 CS Series\* Pre-Digestion Dewatering Centrifuge

CS Series Dewatering Centrifuge, the most efficient in the industry, is designed and built from what was learned in the field by servicing competitors equipment in both municipal and industrial applications.

- **The Rotodiff® hydraulic scroll drive—our standard backdrive technology from day one**
- Highest G-volume and torque capacity
- Increase solids handling
- Reduce polymer consumption
- Continuous operation
- Lowest installed horsepower
- Driest cake
- Customizable for unique application requirements



\*Also see information in #10.

## 7 CalPrex™ Pre-Digestion P-Recovery as Brushite

CalPrex maintains a 6.5 pH, recovers phosphorus as a brushite crystal with up to 41% P<sub>2</sub>O<sub>5</sub> and can minimize digester and sidestream P-loading by over 50%.

- Over 60% solubilization of P in Bio-P sludge
- **Divert over 50% of the soluble P from the digester**
- Reduce up to 50% of the total P in biosolids
- Reduce struvite buildup in the methane digester
- No ammonium required



## 8 KomBio Reactor (Methanogenic Digester) Distributor for LIPP America Tank Systems

KomBio Reactor is a patented digester with an integrated gas storage. The steel shell protects the **integrated gas accumulator** from UV-radiation and harsh weather conditions. The roof decreases the required heat output during winter.

- 26,000 to 660,000 gallons
- Low process energy consumption
- Zero maintenance and long service life
- Quick assembly with the double-seam system
- Corrosion resistance with the "Verinox" stainless steel interior lining system
- CHP container design, available upon request



## 9 AirPrex® Post-Digestion P-Recovery as Struvite

AirPrex is the most cost-effective solution, giving all sized plants the affordable option to control struvite and recover phosphorus. It expands the nutrient recovery focus beyond the production of struvite.

- Reduce and stabilize nutrient loading in the return sidestream to the wastewater treatment line
- **Improve sludge dewaterability**
- Reduce polymer consumption up to 30%
- Reduce maintenance up to 50%
- No sodium hydroxide required
- Reduce struvite precipitation by harvesting, sequestration or centrate recovery



## 10 CS Series\* Post-Digestion Dewatering Centrifuge

CS Series can provide an ROI in as little as 1.5 years with a decrease in maintenance and operating costs.

- **Lowest measured energy consumption\*\***
- Reduce operating and maintenance costs
- Reduce disposal costs
- Highest torque to weight ratio

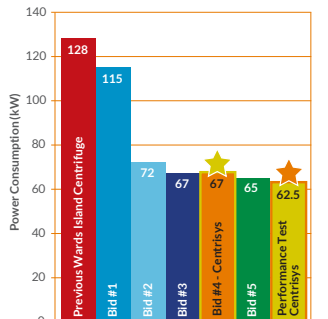

\*Also see information in #6.

\*\*Based on NYC Wards Island performance test in 2017.

## 11 Compact Dry (Low-Temperature Belt Dryer) Distributor for Sülzle Klein GmbH

Compact-Dry is a dual belt, low-temperature belt dryer that can reduce biosolids volume by a third and convert biosolids to Class A.

- Reduce plant operating costs and carbon emissions by reusing waste heat
- Increase safety with low-temperature and minimal dust within the dryer
- **Dried sludge in a granular form with a dryness level of 70-90+%**
- Optimized air-flow system guarantees uniform drying



“ In one year’s time, the utility’s biosolids facilities were transformed to a state-of-the art biosolids and energy showpiece. Complete cooperation of all project partners was integral to achieving success on this challenging project. ”

**Ed Nevers**  
Donohue & Associates Senior Vice President & Kenosha Water Utility Project Manager



## **Centrisys/CNP Enhances Lab Services with Advanced Equipment and Talent**

*Process Team Works within Organization and with Clients to Determine Proper Equipment for Applications*

In an industrial park located in Kenosha, Wisconsin, a group of talented individuals is working together to continue the advancement of their solids handling technologies. These engineers work for one company, but different divisions: equipment manufacturing and biosolids treatment. By combining their efforts, the Centrisys/CNP process and R&D teams are raising the bar to tackle even the most difficult sludge handling and optimization challenges.

Since 1987, Centrisys has been a manufacturer of decanter centrifuge technology for dewatering and thickening in municipal and industrial applications. The company recently added to its equipment portfolio with the award winning THK Sludge Thickener and the SP Series Screwpress. The CNP division, acquired in 2014, offers Airprex® and CalPrex™, nutrient recovery process technologies, and PONDUS™, a Thermo-Chemical Hydrolysis Process (TCHP) for sludge optimization. Working together, Centrisys/CNP can offer customers sludge testing and analysis necessary to problem solve above and beyond the normal capabilities of a typical manufacturer.

The Centrisys/CNP lab and testing services is headed by Hiroko Yoshida, Centrisys R&D Director. Yoshida earned her PhD in Environmental Engineering from the Technical University of Denmark, a Masters in Water Resources Management and a Masters in Civil and Environmental Engineering from the University of Wisconsin-Madison. “Yoshi,” as she is called by the team, began working for Centrisys just over two years ago. She is a key developer working with customized solutions using emerging, innovative equipment and processes. Yoshida is passionate about the advantages of incorporating testing and analysis services from the very beginning of every job.

Patrick Mullen, a CNP Project Manager and Process Engineer, first joined the group in 2015. As an undergraduate at Marquette University in Civil Engineering he went on to receive his masters of science in Environmental Engineering from Marquette studying nutrient removal and recovery from municipal wastewaters. Mullen has worked in both Centrisys and CNP process groups primarily pilot testing the combined benefits of CNP’s AirPrex technology with Centrisys dewatering centrifuges. Yoshida and Mullen find working together as a team serves the clients best in determining which equipment and/or environmental technologies will fit treatment plants goals or help to solve a customer’s environmental problem.

Initially, Centrisys and CNP had individual process engineer departments; these are the engineers that are onsite for pilot testing and/or R&D analysis. But the company quickly came to the conclusion that merging these two teams allows for customers to benefit from stronger more comprehensive lab and pilot testing services.

It’s this cohesive layer, a combination of mechanical, chemical and environmental experience that benefits the Centrisys/CNP lab; having a broad understanding of not only the equipment, but the complete process and the treatment plant. It’s the synchronization between these departments, and divisions that ensure the Centrisys/CNP customers are buying the right equipment for their plant or process.

Centrisys/CNP has a true advantage in understanding the more difficult sludge applications and how to balance the biosolids process along with the equipment. They have years of experience with environmental equipment and know how the equipment handles all different types of sludge. For example, some types of sludge require pre-treatment and conditioning prior to entering a centrifuge to achieve optimal results. According to Yoshi this is critical, as she explains, “Our process engineers need to know what is being fed into the equipment in order to provide a quote, determine the size or recommend other options. In the case of a centrifuge, it’s mainly limited by flow, the solids loading and nature of how well it compacts. In the case of CNP, however it can be more complicated.”

“As utilities look to push the limits of the wastewater treatment process by adding energy and nutrient recovery to their systems, such as AirPrex, CalPrex, and Pondus, we know that these processes may change the sludge characteristics going into the centrifuge and affect conditioning strategies,” Mullen says. “By combining Centrisys and CNP lab testing protocols we can anticipate what benefits or changes we might see at full scale.”

Centrisys/CNP also offers pilot testing for the THK Sludge Thickener, another part of the biosolids process which thickens sludge. The nutrient recovery technologies AirPrex and CalPrex, especially important when dealing with industrial and digested biosolids, each have pilot testing units. “We’re more than an OEM provider,” Yoshida says. “Today, in order to sell environmental technologies you have to offer more. You need to get your hands dirty to turn innovation into reality, or help customers solve their environmental challenges.”

Centrisys/CNP will introduce the CS6-4 centrifuge at WEFTEC 2018 on October 1-3, 2018 in New Orleans. The Centrisys CS6-4 bridges the gap between benchtop studies and full scale installations. The CS6-4 continuously treats flows from 4-10 gpm, making this centrifuge a preferred alternative to a conventional laboratory centrifuge, which processes samples in batches. The CS6-4 provides scalable solid-liquid separation data to move R&D projects forward.

“Making continuous improvements in our lab and process departments are paramount to the success of Centrisys/CNP” according to Michael Kopper, CEO/Founder Centrisys/CNP. “Quality doesn’t just start in engineering or on the manufacturing floor. It starts at the very beginning and that’s in the lab or on a pilot test.”

*Centrisys Corporation is a U.S.A. manufacturer of dewatering centrifuges, sludge thickeners and complete dewatering systems for municipal and industrial wastewater. The company’s focus is centrifuge equipment, including the award winning THK sludge thickener. Centrisys provides global service, repair and parts for all brands of centrifuges. CNP - Technology Water and Biosolids designs and supplies nutrient recovery and biosolids treatment optimization systems. CNP’s key technologies are: AirPrex® and CalPrex™, phosphorus recovery technologies, and PONDUS™, a Thermo-Chemical Hydrolysis Process (TCHP). CNP is a division of Centrisys Corporation.*

*Photo Captions:*

Photo 1: Hiroko Yoshida, R&D Director, oversees Amanda Eness, Lab Technician, conduct a sludge volume index (SVI) measurement for sludge thickening.

Photo 2: Daniel Anderson and Xu Ye, both Process Engineers, use the control panel to optimize the dewatering centrifuge on the Centrisys/CNP pilot trailer.

**For more information, please contact:**  
Centrisys Corporation

9586 58th Place  
Kenosha, WI 53144  
262-654-6006  
Jessie Jones, Marketing Associate  
Email: [Jessie.jones@centrisys.us](mailto:Jessie.jones@centrisys.us)  
Website: [www.centrisys.com](http://www.centrisys.com)

**Centrisys/CNP Announces Exclusive U.S. Distributorship for the  
Passavant® hydrograv® adapt System**

Centrisys/CNP (Kenosha, WI), a leader in decanter centrifuge technology and systems for nutrient recovery and sludge optimization, has announced their exclusive distributorship for the Passavant hydrograv adapt System in North America (U.S. patent pending).

Unlike fixed inlet structures for secondary clarifiers, the Passavant hydrograv adapt System consistently and continuously adjusts to current loading in a clarifier. If the loads are low, the hydrograv adapt automatically shifts the inlet elevation and opening height to a low position, introducing the mixed liquor below the sludge blanket. As the loads increase, the hydrograv adapt system shifts itself to a higher elevation and opening height, ensuring ideal hydraulic conditions for the operation of the secondary clarifiers and avoiding sludge overflow.

Benefits of the Passavant hydrograv adapt System include improved process stability of secondary clarification, a reduction of effluent suspended solids to usually less than 3 mg/L, improved particulate phosphorus removal, improved clarification capacity from hydraulic optimization and overall low maintenance requirements.

At WEFTEC 2018, Dr. Martin Armbruster, the Managing Director and founder of hydrograv GmbH and the inventor of the hydrograv adapt system, will co-present on the topic of “Stress Testing of a Secondary Clarifier with an Adaptive Inlet Structure.” His expertise in the field of clarifier CFD simulation includes optimization and practical engineering for more than 1,000 clarifiers in 200+ treatment plants worldwide. His experience in improving hydraulic efficiency of water management systems is based on 500+ hydrograv® with CFD simulations installations. The seminar will take place on Wednesday, October 3 at 1:50 p.m. in room 239.

**If you are unable to attend the seminar on October 3, Centrisys/CNP (booth #4921) will hold an in-booth discussion with Dr. Armbruster on Tuesday, October 2 at 2 p.m.**

*Centrisys Corporation is a U.S.A. manufacturer of dewatering centrifuges, sludge thickeners and complete dewatering systems for municipal and industrial wastewater. The company's focus is centrifuge equipment, including the award winning THK sludge thickener. Centrisys provides global service, repair and parts for all brands of centrifuges. CNP - Technology Water and Biosolids designs and supplies nutrient recovery and biosolids treatment optimization systems. CNP's key technologies are: AirPrex® and CalPrex™, phosphorus recovery technologies, and PONDUS™, a Thermo-Chemical Hydrolysis Process (TCHP). CNP is a division of Centrisys Corporation.*

For more information, please contact:

Centrisys Corporation  
9586 58th Place  
Kenosha, WI 53144  
262-654-6006  
Jessie Jones, Marketing Associate  
Email: [Jessie.jones@centrisys.us](mailto:Jessie.jones@centrisys.us)  
Website: [www.centrisys.com](http://www.centrisys.com)

**The Centrisys/ CNP THK Sludge Thickener Improves Municipal and Industrial Wastewater Applications**  
*With eight purchase orders in the last 3 months, the company's sludge thickener has been used in several wastewater treatment facilities and wineries.*

In the last few years, the U.S. has undergone a series of innovations and technology advancements. These changes have impacted several industries, leading them to save energy and resources. One such industry is wastewater treatment. Seven wastewater treatment plants in San Antonio, TX; Lincoln, NE; Belvidere, IL; Grandville, MI; Fargo, ND; University of Florida, Beijing airport and an East coast winery have benefited from the Centrisys/CNP THK sludge thickener. It offers proven performance with lower life cycle costs, less or zero polymer, higher G-volume for higher capacity and less redundancy, as well as up to 50% less power consumption compared to standard dewatering centrifuges.

"I'm surprised it's taken this long for other treatment plants to see the value of this piece of equipment. The Kenosha WWTP (Wastewater Treatment Plant) installed our first THK200 in 2011. This one machine replaced four DAFT units, operated 24/7 using no polymer and achieved 5% TS cake and 95% capture. In 2015, we upgraded our plant process and now have an additional THK200 for primary sludge. With this THK, we doubled our solids concentration and cut in half the amount of water sent to the digesters," said Melissa Arnot, P.E. Director of Operations at Kenosha Water Utility.

The basis of the THK design highlights what Centrisys is best known for – centrifuges. This sludge thickener is not a modified dewatering centrifuge, which is typically what happens when a conventional dewatering centrifuge is used for thickening sludge. The THK sludge thickener is designed and built specifically to thicken both primary and waste activated sludge using the fundamental principles of a centrifuge, DAFT and Rotary Drum Thickener.

According to Centrisys/ CNP's CEO, Michael Kopper, "Equipment in this industry should last for decades. Those decision makers who understand the increasing importance of lower lifecycle costs and higher process efficiencies are clearly making the right choices for their plants and ultimately rate payers and our environment."

**Visit Centrisys/CNP at WEFTEC 2018, booth #4921.**

*Centrisys Corporation is a U.S.A. manufacturer of dewatering centrifuges, sludge thickeners and complete dewatering systems for municipal and industrial wastewater. The company's focus is centrifuge equipment, including the award winning THK sludge thickener. Centrisys provides global service, repair and parts for all brands of centrifuges. CNP - Technology Water and Biosolids designs and supplies nutrient recovery and biosolids treatment optimization systems. CNP's key technologies are: AirPrex® and CalPrex™, phosphorus recovery technologies, and PONDUS™, a Thermo-Chemical Hydrolysis Process (TCHP). CNP is a division of Centrisys Corporation.*

**For more information, please contact:**

Centrisys Corporation  
9586 58th Place  
Kenosha, WI 53144  
262-654-6006

Jessie Jones, Marketing Associate  
Email: [Jessie.jones@centrisys.us](mailto:Jessie.jones@centrisys.us)

Website: [www.centrisys.com](http://www.centrisys.com)

### **Centrisys/CNP Announces New Technologies at WEFTEC 2018**

Centrisys/CNP (booth #4921) will showcase their “More with Less” approach to innovation in the areas of sludge and biosolids management – including thickening, dewatering, resource intensification and nutrient recovery at WEFTEC 2018, October 1-3 in New Orleans.

Centrisys will introduce their new CS6-4 dewatering centrifuge, their smallest centrifuge to date. The CS6-4 bridges the gap between benchtop studies and full-scale installations. The CS6-4 continuously treats flows from 4 to 10 gpm, making this centrifuge a better alternative to a conventional laboratory centrifuge, which processes samples in batches. The CS6-4 provides scalable solid-liquid separation data to move R&D projects forward.

“We introduced the CS-6 into our equipment portfolio because so many of our customers requested it; there was a need and we simply provided a solution” Michael Kopper, CEO Centrisys/CNP.

Additionally, Centrisys will discuss their latest exclusive distributorship for the Passavant® hydrograv® adapt System in North America (U.S. patent pending). Unlike traditional inlet structures for secondary clarifiers, with the hydrograv adapt System, mixed liquor is introduced near the bottom of the clarifier, below the sludge blanket. The inlet elevation and opening height adjusts to flow conditions so it is always operating in ideal hydraulic conditions.

Centrisys will hold an in-booth discussion with Dr. Armbruster, the Managing Director and founder of hydrograv GmbH and the inventor of the hydrograv adapt system, on Tuesday, October 2 at 2 p.m. Additionally, Centrisys/CNP equipment and processes will be highlighted in the following seminars at WEFTEC 2018:

- **Digestion: Let Me Upgrade You** / Tuesday, Oct. 2 at 4:00 p.m. / Room 244
- **Advances in Solid Clarification** / Wednesday, Oct. 3 at 1:50 p.m. / Room 239
- **Sidestream Impacts from Startup to Implementation** / Wednesday, Oct. 3 at 3:30 p.m. / Room 354
- **Expectations Exceeded? Promises Met?** / Wednesday, Oct. 3 at 4:00 p.m. / Room 344

#### **Visit Centrisys/CNP at WEFTEC 2018, booth #4921.**

*Centrisys Corporation is a U.S.A. manufacturer of dewatering centrifuges, sludge thickeners and complete dewatering systems for municipal and industrial wastewater. The company's focus is centrifuge equipment, including the award winning THK sludge thickener. Centrisys provides global service, repair and parts for all brands of centrifuges. CNP - Technology Water and Biosolids designs and supplies nutrient recovery and biosolids treatment optimization systems. CNP's key technologies are: AirPrex® and CalPrex™, phosphorus recovery technologies, and PONDUS™, a Thermo-Chemical Hydrolysis Process (TCHP). CNP is a division of Centrisys Corporation.*

#### **For more information, please contact:**

Centrisys Corporation  
9586 58th Place  
Kenosha, WI 53144  
262-654-6006

Jessie Jones, Marketing Associate  
Email: [Jessie.jones@centrisys.us](mailto:Jessie.jones@centrisys.us)  
Website: [www.centrisys.com](http://www.centrisys.com)



# AirPrex®

Sludge Optimization and  
P-Recovery



## THE PROBLEM

Struvite Mineral Buildup Leads to **Reduced** Plant Capacity

In wastewater reclamation plants with Biological Phosphorus Removal (BPR), phosphorus accumulates in sludge and releases in a dissolved reactive form (orthophosphate) in an anaerobic condition.

Elevated orthophosphate levels in sludge causes operational challenges, including:

- Deterioration of sludge dewaterability
- Elevated phosphorus load to the wastewater treatment plant due to phosphorus recirculation
- Uncontrolled formation of struvite (or MAP: magnesium ammonium phosphate) inside pipes and other equipment
- Reduced digester capacity by struvite build-up inside the anaerobic digester

## THE SOLUTION

AirPrex **Optimizes** the Sludge Treatment Process Like No Other System

AirPrex turns struvite into an opportunity for resource recovery. Struvite, when formed under a controlled environment, can be harvested and utilized as a beneficial fertilizer. AirPrex forms struvite by stripping out CO<sub>2</sub>, elevates the pH and adds MgCl<sub>2</sub> to augment Mg<sub>2</sub><sup>+</sup>. AirPrex installs between the anaerobic digester and the dewatering equipment. The process converts the orthophosphate into struvite crystals, which is harvested from the bottom of the reactor. AirPrex mitigates the unexpected consequence of dewatering Bio-P sludge.

## THE BENEFITS

AirPrex Removes Struvite while Significantly **Improving Treatment Efficiency**



Reduce Polymer Consumption up to **30%**



Reduce Disposal Costs up to **20%**



Reduce Phosphate Recycle Load up to **90%**



Reduce Maintenance Costs up to **50%**



Increase Revenue from Fertilizer up to **20%**

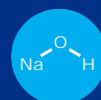

**No** Sodium Hydroxide Required

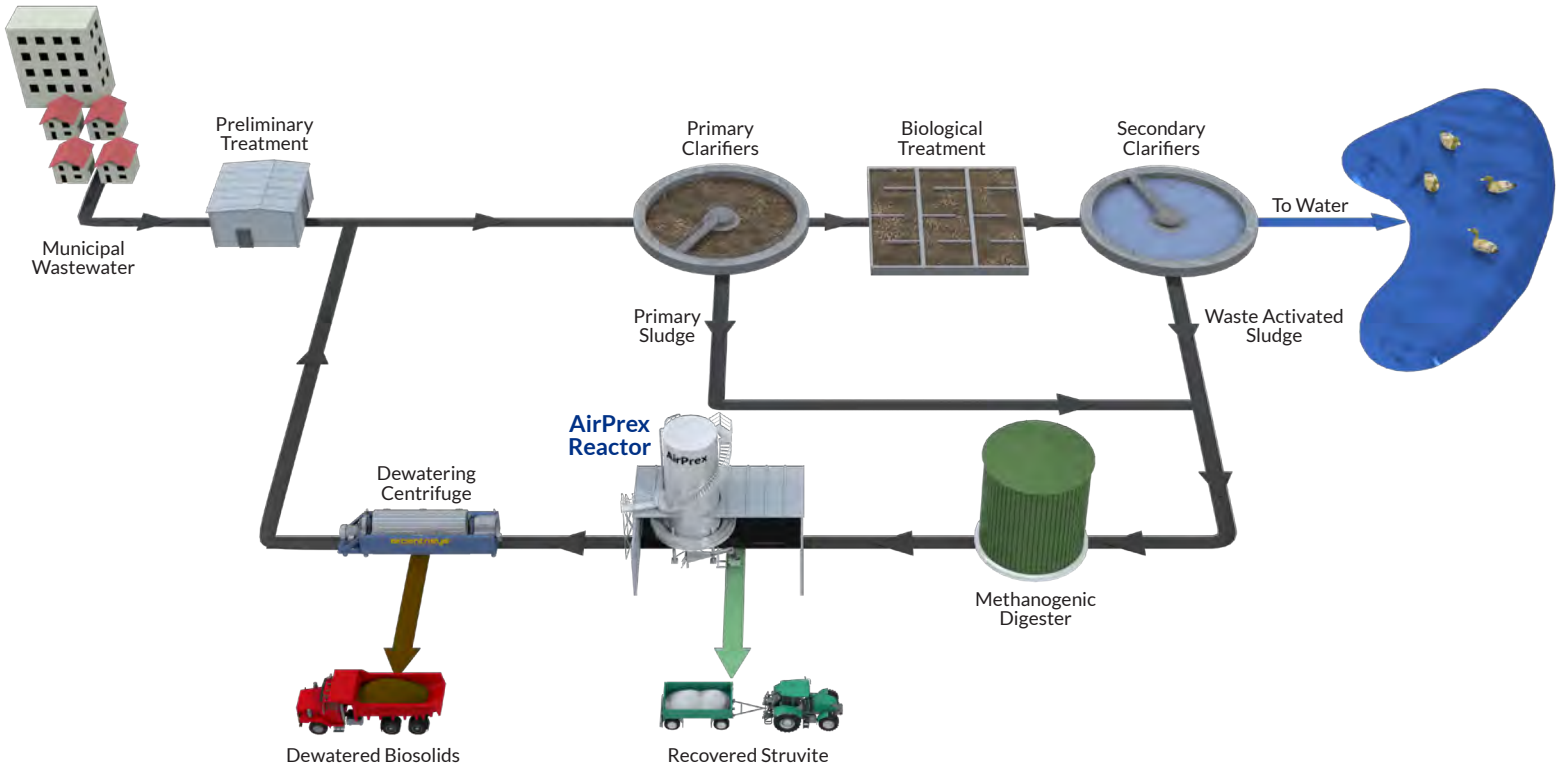

	Centrate Recovery	WAS Fermentation + Centrate Recovery	AirPrex®
Reduce Phosphorus Recycle	✓	✓	✓
Recovery of Marketable Fertilizer	✓	✓	✓
Reduce Struvite Maintenance	✓	✓	✓
Improve Sludge Cake Dryness	✗	?	✓
Reduce Polymer Demand	✗	?	✓
No Recovery Option (Sequestration)	✗	✗	✓
Cost Competitive for Small Utilities	✗	✗	✓

Questions about CNP technologies?

**Corporate** 9586 58th Place | Kenosha, WI 53144 USA P +1 (262) 654-6006 E info@cnp-tec.us  
**Global Presence** North America | South America | Europe | Middle East | China

© CENTRISYS CORPORATION | No part of this copyrighted work may be reproduced, modified or distributed in any form or by any means, or stored on any database or retrieval system, without the prior written permission of CENTRISYS CORPORATION or its affiliates. Any such unauthorized use for any purpose is a violation of the relevant copyright laws.



## Around the World, AirPrex Provides a Simple, Flexible and Right-Sized Solution for Phosphorus Recovery

AirPrex is a pioneering nutrient recovery technology developed for the sludge treatment process.

### Right-Sized Solution

AirPrex is the most cost-efficient solution, giving plants of all sizes (including small to mid-size plants) the affordable options to control struvite and recover phosphorus.

### Beyond the Fertilizer Model

AirPrex expands the nutrient recovery focus beyond the production of marketable fertilizer by:

- Reducing struvite precipitation
- Improving sludge dewaterability
- Reducing and stabilizing nutrient loading in the sidestream to the wastewater treatment line

These tangent benefits provide cost savings and shields utilities away from fertilizer production

### Partnership Approach

The Airprex process focuses on total treatment optimization, not only fertilizer production. AirPrex provides:

- Harvesting: from digested sludge
- Sequestration: leaves the crystals in the sludge
- Centrate Recovery: produces a high purity product

These three operation models allow the CNP engineers to work with utilities and determine the best fit configuration to meet plant's objectives.

## QUICK GLANCE

### AirPrex by the Numbers



**10** Full Scale Installations Since 2009



Flexible Solution for Plants of All Sizes (**9 to 170 MGD**)



**3** Process Configurations (Harvesting, Sequestration and Centrate Recovery)



Reduce Orthophosphate in **48 Hours**



**Mobile** Pilot Test Unit Available



**No** Sodium Hydroxide Required

Full Scale Installations				After AirPrex		
Wastewater Treatment Plant	Location	Year Built	Plant Size MGD	Orthophosphate Reduction (%)	Dry Cake Solids Increase (%-points)	Polymer Reduction (%)
Mönchengladbach-Neuwerk (Niersverband) WWTP	Mönchengladbach-Neuwerk, Germany	2009	80	>90	+3	-15
Berlin Wasserbetriebe (BWB) WWTP	Berlin, Germany	2010	120	>90	+3 to 4	-20
Wieden-Echten (Reest & Wiedn) WWTP	Echten, Netherlands	2013	30	>90	+3	-15
Amsterdam-West (Waternet) WWTP	Amsterdam, Netherlands	2014	170	>90	+3	-25
ASG Salzgitter North WWTP	Salzgitter, Germany	2015	20	>90	+2	-15
Jing Nan Tianjin WWTP	Tianjin, China	2016	120	>90	Centrate Recovery	
Wolfsburg Entwässerungsbetriebe (WEB) WWTP	Wolfsburg, Germany	2017	25	>95	+2	NA*
Liverpool WWTP	Medina, Ohio	2018 Start-Up	15		Pending Start-Up	
Little Patuxent Water Reclamation Plant, Howard County	Savage, Maryland	2018 Start-Up	29		Pending Start-Up	
RWH Treatment Facility at Metro WWRD	Denver, Colorado	2019 Start-Up	220	>90**	+4 to 5**	-15 to -25**

Pilot Tests						
Fond du Lac WWTP	Fond du Lac, Wisconsin	October 2015	4	>90	+2	-15
Fox River Water Reclamation District	Elgin, Illinois	November 2015	25	>90	+2	-10
Miami-Dade South District Plant	Miami, Florida	April 2016	128.5	>90	+4	-10 to -20
Stevens Point WWTP	Stevens Point, Wisconsin	May 2016	3	>90	+5	-25 to -35
Sun Prairie WWTP	Sun Prairie, Wisconsin	October 2016	4	>90	+3	-10 to -25
Tres Rios Water Reclamation Facility	Tucson, Arizona	January 2017	50	>90	+4	-30 to -50

\* AirPrex and the anaerobic digester were implemented at the same time. There is no historical dewatering data to compare. \*\*Pilot test data from 2016

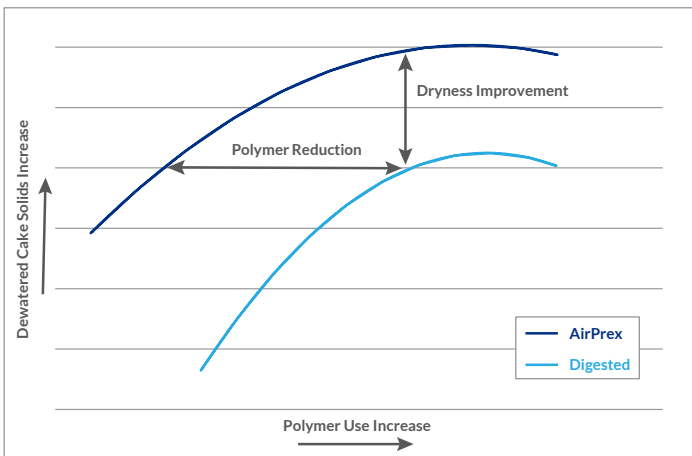

Typical Polymer Curve for Digested Sludge

### Trade-Off Between Polymer Dosage and Cake Dryness

In addition to struvite control, the AirPrex system also provides advantages to the solids dewatering process. AirPrex increases the achievable dewatered cake dryness which allows for a reduction in polymer needed to maintain current plant specification. This dewaterability shift helps reduce the overall chemical cost associated with AirPrex and improve routine operation of dewatering equipment.

## Questions about CNP technologies?

**Corporate** 9586 58th Place | Kenosha, WI 53144 USA **P** +1 (262) 654-6006 **E** info@cnp-tec.us  
**Global Presence** North America | South America | Europe | Middle East | China

© CENTRISYS CORPORATION | No part of this copyrighted work may be reproduced, modified or distributed in any form or by any means, or stored on any database or retrieval system, without the prior written permission of CENTRISYS CORPORATION or its affiliates. Any such unauthorized use for any purpose is a violation of the relevant copyright laws.

# CalPrex™

Pre-Digestion P-Recovery

Photo enlarged for detail.

## THE PROBLEM

### Phosphorus Solubilization **Limits** Recovery Efficiency

Typical struvite based phosphorus recovery technologies recover only 15-30% of the phosphorus entering wastewater treatment plants (including Bio-P plants). Recoverable crystals are only available from soluble and reactive phosphorus (orthophosphate).

## THE SOLUTION

### Acid Phase Digestion: the Biological **Solution** for P Solubilization

An acid phase digester provides a low-oxygen and low-pH environment. This facilitates the rapid release of orthophosphates in Bio-P sludge along with the dissolution of crystallized and organically-bound phosphorus. Over 60% solubilization of P occurs in the acid phase digesters without using any additional chemicals. In non-bio-P plants, up to 40% of the phosphorus solubilizes using an acid phase digester.

A CalPrex reactor is placed between the acid phase and gas phase digesters. Sludge from the acid phase digester is dewatered. The centrate is sent to the CalPrex reactor. The dissolved phosphorus in the centrate precipitates with the addition of calcium hydroxide. By maintaining the pH of the solution at 6.5, phosphorus is recovered as a brushite crystal ( $\text{CaHPO}_4 \cdot 2\text{H}_2\text{O}$ ). As a fertilizer, brushite is comparable to leading phosphate fertilizers on the market today.

## THE BENEFITS

### High Efficiency P-Recovery and Digester Protection



Over **60%** Solubilization  
of P in Bio-P Sludge



Divert Over **50%** of the  
Soluble P from the Digester



Reduce up to **50%** of the  
Total P in Biosolids



Reduce Struvite Buildup in the  
Methane Digester



**No** Ammonium Required

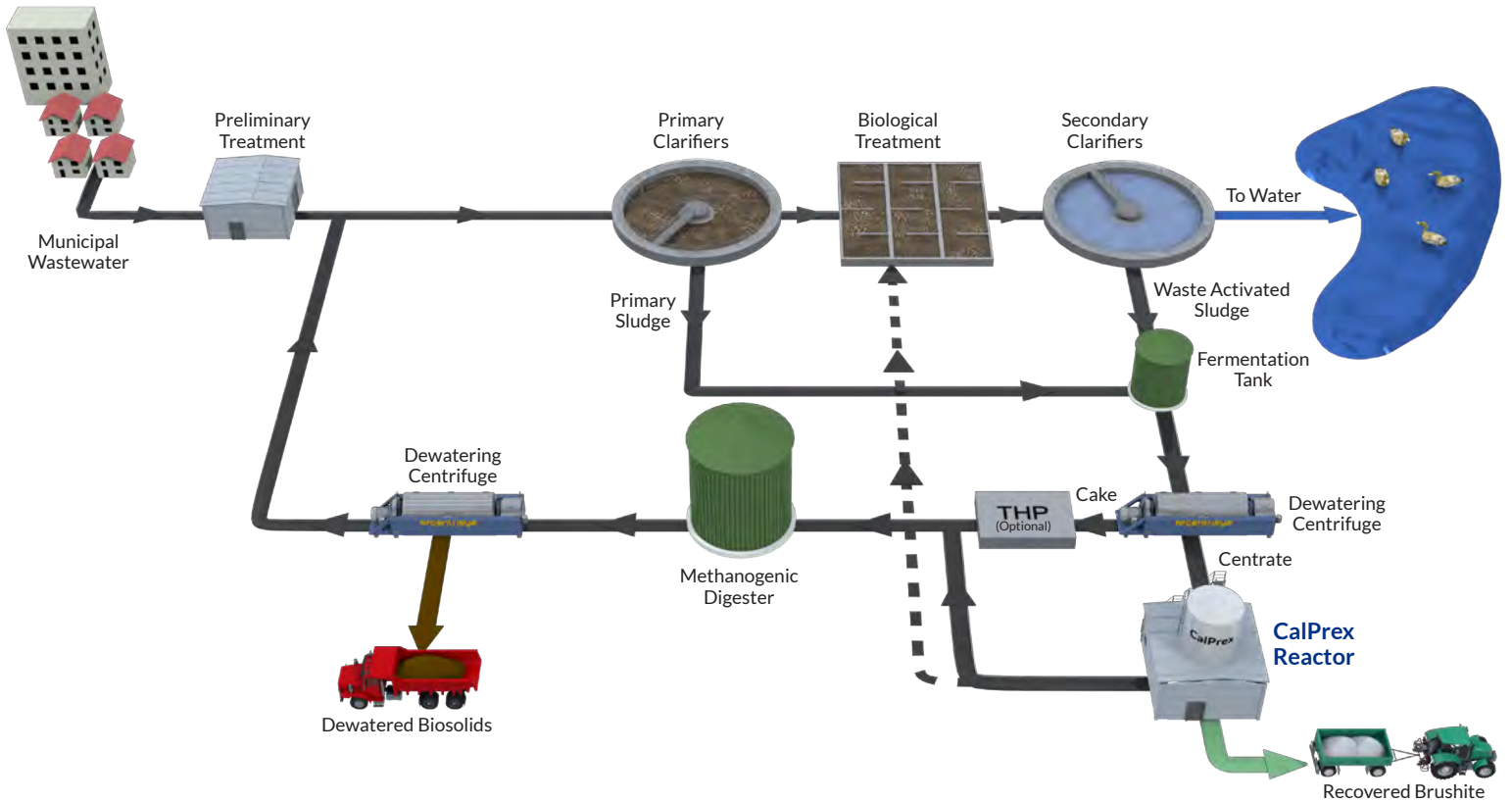

	Centrate Recovery	WAS Fermentation + Centrate Recovery	CalPrex™
Reduce Phosphorus Recycle	✓	✓	✓
Recovery of Marketable Fertilizer	✓	✓	✓
Reduce Struvite Maintenance	✓	✓	✓
Reduce Digester Struvite Buildup	✗	✓	✓
Compact Reactor	✗	✗	✓
Recover P from No/Low Ammonia System	✗	✗	✓
Recover P from Non-Bio-P Plant	✗	✗	✓
Lower Chemical Cost Per P Recovered	✗	✗	✓
Lower Chloride Addition Per P Recovered	✗	✗	✓
High Total P Capture	✗	✗	✓

The CalPrex™ Technology is licensed by Nutrient Recovery and Upcycling LLC.

## Questions about CNP technologies?

**Corporate** 9586 58th Place | Kenosha, WI 53144 USA **P**+1 (262) 654-6006 **E** info@cnp-tec.us  
**Global Presence** North America | South America | Europe | Middle East | China

© CENTRISYS CORPORATION | No part of this copyrighted work may be reproduced, modified or distributed in any form or by any means, or stored on any database or retrieval system, without the prior written permission of CENTRISYS CORPORATION or its affiliates. Any such unauthorized use for any purpose is a violation of the relevant copyright laws.

CNP2018v8EN

# Capture the Most Phosphorus

## CalPrex™

Pre-Digestion P-Recovery

## AirPrex®

Sludge Optimization and P-Recovery

## THE PROBLEM

Phosphorus is a **Limited** Resource

Most phosphorus fertilizer used for modern agriculture originates from phosphate rock. Phosphate rock is a non-renewable resource with limited reserves. To ensure sustainable food production for the future, it is critical to expand the recovery and reuse of phosphorus from waste sources. Prior to the development of CalPrex and AirPrex, the methods to effectively recover phosphorus entering a wastewater treatment plant were to chemically acidify sludge or incinerated ash. These processes are prohibitively expensive if only used for fertilizer production.

## THE SOLUTION

**Maximum** Phosphorus Recovery,  
**Minimum** Sludge Production

The combination of CalPrex + AirPrex captures 50%+ **total** phosphorus entering treatment plants, with minimal addition of chemicals.

The CalPrex process harnesses the acidogenic bacteria power to acidify bio-P sludge. Over 60% of phosphorus solubilizes in the acid phase digestion process. Dewatering acidogenically digested sludge isolates the dissolved phosphorus (orthophosphates) in the centrate. The centrate is sent to the CalPrex reactor, where orthophosphates are precipitated by calcium hydroxide. By maintaining a pH solution of 6.5 or below, phosphorus is recovered as brushite ( $\text{CaHPO}_4 \cdot 2\text{H}_2\text{O}$ ), a market-ready, high-quality fertilizer.

AirPrex converts the remaining orthophosphates in digested sludge to struvite ( $\text{MgNH}_4\text{PO}_4 \cdot 6\text{H}_2\text{O}$ ) by air stripping  $\text{CO}_2$  and adding magnesium chloride. Struvite is another market-ready fertilizer. AirPrex reduces the phosphorus recirculation by 90%.

## THE BENEFITS

CalPrex + AirPrex:  
A **Combined** Approach



Reduce Phosphate Recycle Load up to **90%**



Reduce Polymer Consumption up to **30%**



Reduce Disposal Costs up to **20%**



Reduce Maintenance Costs up to **50%**



Recover Over **50%** of **Total** Phosphorus

# TECHNOLOGY OVERVIEW: CalPrex™ & AirPrex®

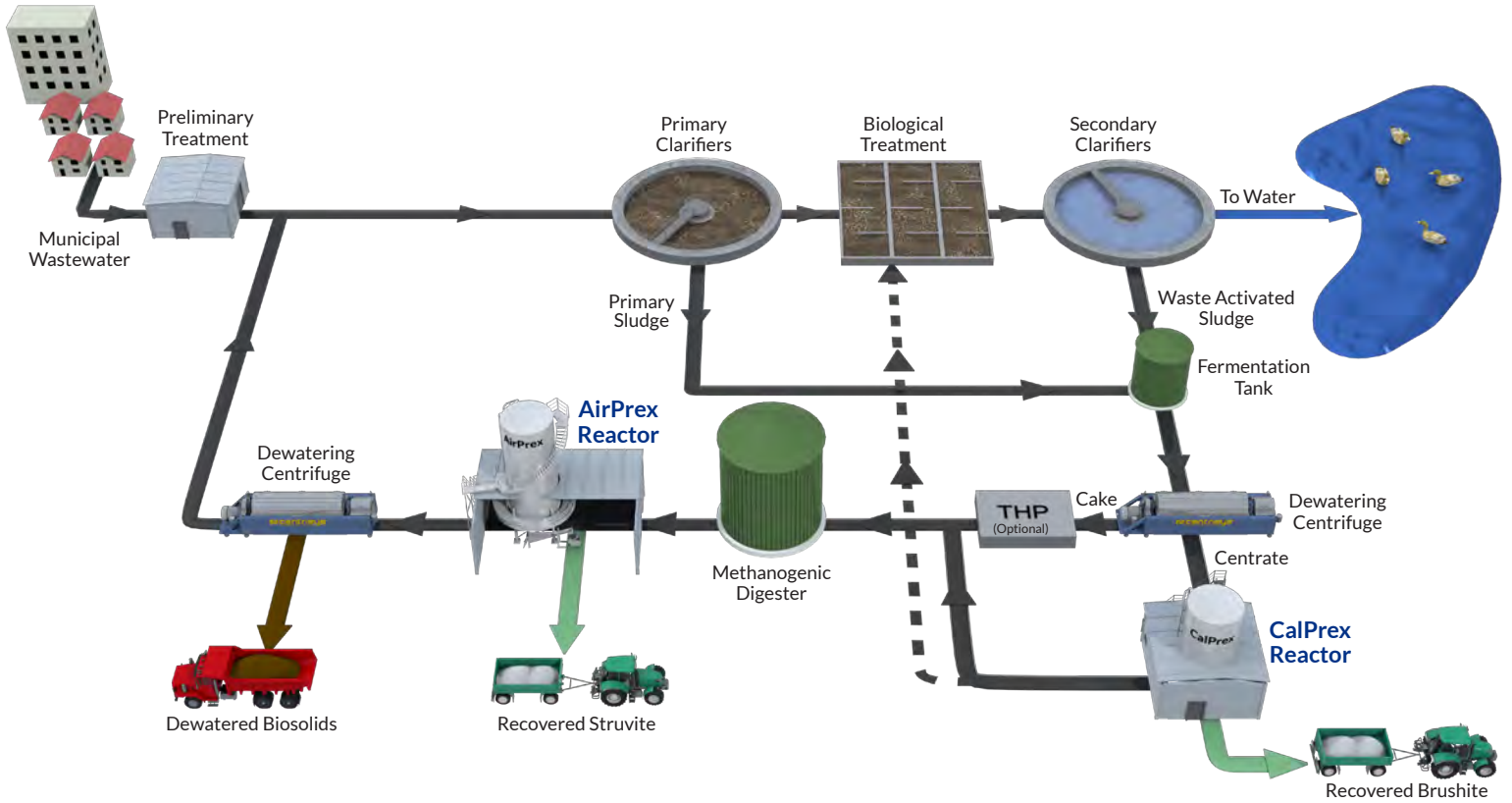

	Centrate Recovery	WAS Fermentation + Centrate Recovery	AirPrex®	CalPrex™	AirPrex® & CalPrex™
Reduce Phosphorus Recycle	✓	✓	✓	✓	✓
Recovery of Marketable Fertilizer	✓	✓	✓	✓	✓
Reduce Struvite Maintenance	✓	✓	✓	✓	✓
Reduce Digester Struvite Buildup	✗	✓	✗	✓	✓
Improve Sludge Cake Dryness	✗	?	✓	?	✓
Reduce Polymer Demand	✗	?	✓	?	✓
Reduce P Content of Sludge	✗	✓	✗	✓	✓
Compatible with THP or TCHP* Addition	✗	✓	✓	✓	✓
Lower Chemical Cost Per P Recovered	✗	✗	✗	✓	✓

\*Thermal Hydrolysis Process or Thermo-Chemical Hydrolysis Process

The CalPrex™ Technology is licensed by Nutrient Recovery and Upcycling LLC.

## Questions about CNP technologies?

**Corporate** 9586 58th Place | Kenosha, WI 53144 USA P +1 (262) 654-6006 E info@cnp-tec.us  
**Global Presence** North America | South America | Europe | Middle East | China

© CENTRISYS CORPORATION | No part of this copyrighted work may be reproduced, modified or distributed in any form or by any means, or stored on any database or retrieval system, without the prior written permission of CENTRISYS CORPORATION or its affiliates. Any such unauthorized use for any purpose is a violation of the relevant copyright laws.

CNP/CA2018V3EN



# In the Thick of It

Keep the hydrolysis process  
**simple | affordable | safe**  
 for all sized plants



## What is PONDUS™ Thermo-Chemical Hydrolysis Process (TCHP)?

PONDUS, an alkaline process, utilizes low grade heat (160 °F to 180 °F) and sodium hydroxide for sludge hydrolysis. A typical PONDUS system consists of a hydrolysis reactor, hot water heat exchanger, chemical dosing station, pumps, instrumentation and controls. PONDUS reduces sludge viscosity, enhances biogas production and improves sludge dewaterability.

## The PONDUS Difference

- No heat exchangers needed to cool sludge after hydrolysis to maintain an optimum digester temperature
- No steam required
  - ✓ Safer operation
  - ✓ Specialized steam operator is not necessary
  - ✓ Reduces operating and energy costs
- Combination of caustic soda (NaOH) and heated water, 140 °F to 160 °F, break down the cell walls
- Minimal equipment needed: high-efficiency heat exchanger, progressive cavity pumps and a reactor operating under at atmospheric pressure
- No pressure vessel tanks required

## PONDUS is Simple to Operate

PONDUS is designed to utilize low grade heat (from hot water), rather than steam, as a heat source for sludge hydrolysis. A Certified Steam Boiler License is not required to operate the system. PONDUS' design allows it operate the atmospheric pressure without involving a pressurized vessel. Maintaining PONDUS is easy. Typical maintenance includes: pump maintenance, heat exchanger cleaning, and sodium hydrolyzed refilling.

## PONDUS Optimizes Your Sludge Treatment Process



Reduce Viscosity of Thickened WAS up to **80%**



Reduce Anaerobic Digestion Volume up to **50%**



Improve Biosolids Dewatering up to **5%**



Increase Biogas Production up to **30%**



Reduce Polymer Consumption at Dewatering up to **20%**



Reduce Digester Foaming

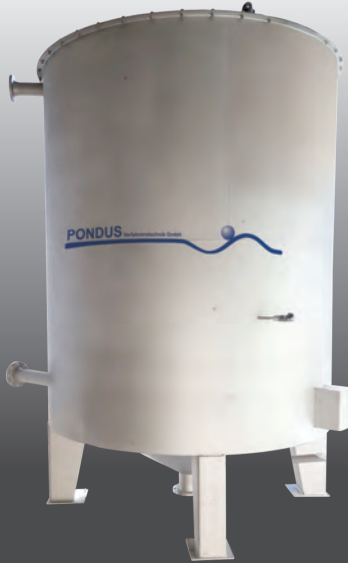

## PONDUS is a Cost-Effective Choice

- Simple operation requires little day-to-day plant supervision
- Fully automatic process runs 24/7 year-round
- 99% uptime; minimal estimated downtime for maintenance and repairs
- Designed using standard industrial control system equipment
- Compact; small footprint solution for all sized plants

## PONDUS Step-By-Step

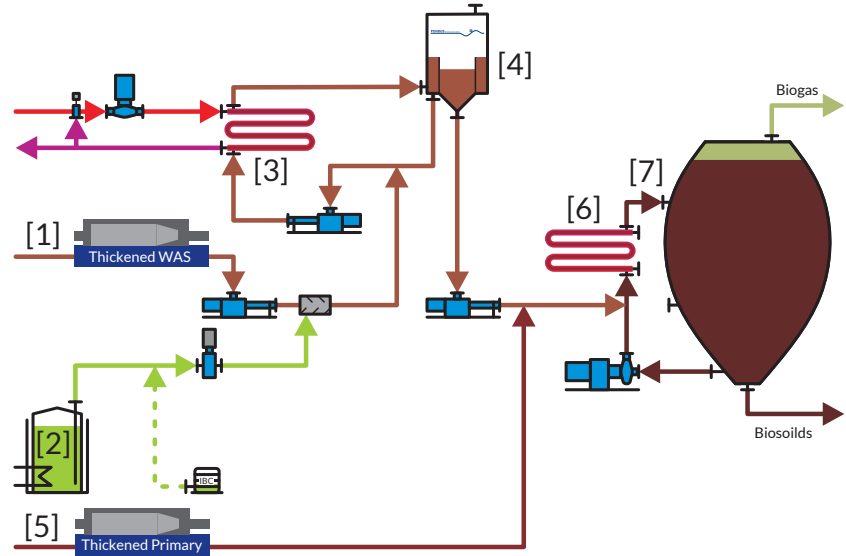

[1] Thickened WAS is mixed with a small dose of [2] caustic soda (1.75 l/m<sup>3</sup>).

[3] Sludge is heated in a loop through a high-efficiency heat exchanger.

[4] Sludge is fed into PONDUS and goes through hydrolysis. The sludge is heated with 140 °F to 160 °F water from a Combined Heat and Power (CHP) unit or boiler. Retention time may differ in reactor zones due to varying sludge properties. The reactor operates under atmospheric pressure and is connected to the atmosphere or bio-filter. After the hydrolysis process, sludge leaves the reactor close to a neutral pH level and the remaining thermal energy can be used in the anaerobic digester [7].

[5] Thickened primary sludge and hydrolyzed sludge is mixed to achieve an ideal mesophilic temperature of the combined sludge and then pumped into the digester [7]. If needed, additional heat can be brought into the digester through a [6] heat exchanger.

## PONDUS Full Scale Installations

Wastewater Treatment Plant	Location	Year Built	Plant Size (MGD)	After PONDUS	
				Additional Gas Production	Note
Kläranlage Gifhorn	Gifhorn, Germany	2005	14	27%	24-hr operation
Kläranlage Ratekau	Ratekau, Germany	2007	13	38%	12-hr operation, Class A possible
Nordhorn Kommunale Betriebe AöB	Nordhorn, Germany	2014	16	25%	24-hr operation, Class A possible
Kläranlage Uelzen	Uelzen, Germany	2014	13	31%	24-hr operation
Kenosha Wastewater Treatment Plant	Kenosha, Wisconsin	2015	28	27%	24-hr operation since March 2016
Kläranlage Wolfsburg	Wolfsburg, Germany	2016	34	N/A*	24-hr operation
Löhne-Rießel Wastewater Treatment Plant	Löhne, Germany	2019 Start-Up	14		Pending Start-Up
Wuwei Sludge Treatment Center	Wuwei, China	2020 Start-Up	106		Pending Start-Up

\* PONDUS and the anaerobic digester were implemented at the same time. There is no historical biogas production data to compare.

## Questions about CNP technologies?

**Corporate** 9586 58th Place | Kenosha, WI 53144 USA P +1 (262) 654-6006 E info@cnp-tec.us  
**Global Presence** North America | South America | Europe | Middle East | China

# Geoffrey Harvey

## Electrical Engineering Director

### Issue:

Many municipalities are using legacy wastewater treatment systems that are three or four decades old. While these systems can still get the job done, advancements in the technology offer significant opportunities to improve efficiency, performance, reliability and cost savings. By attacking these challenges head on, forward-thinking engineers are helping to advance the industry.

#### Water and Wastewater Treatment Publications

can turn to Centrisys Corporation's Geoffrey Harvey, an innovative electrical engineer, for a first-hand account of how to troubleshoot and diagnose electrical and/or programming problems.



**Geoffrey Harvey**  
Electrical Engineering  
Director

### Biography

Harvey joined Centrisys in 2004 and has over 20 years of experience in electrical engineering and design for decanter centrifuges. Harvey knew he wanted a career that constantly challenges his abilities - from designing and programming complex control systems to troubleshooting electrical and programming challenges. In Centrisys, Harvey found precisely that.

As head of the electrical engineering department, Harvey leads a team of six electrical engineers. His team designs, develops and programs custom control systems, primarily for wastewater treatment and completes 40 to 50 custom systems annually.

Today, wastewater facilities face the problem of updating older electrical control systems as these are quickly becoming obsolete due to technological advancements. Harvey and his team deliver troubleshooting and diagnostics solutions addressing the often difficult-to-diagnose electrical problems for control systems.

Harvey earned a Bachelor of Science Degree in Management with an Industrial Management focus from the University of Wisconsin-Stout and Associate of Science Degrees in Electrical Engineering and Supervisory Management from Gateway Technical College. Harvey is currently pursuing his Masters in Engineer Management at Milwaukee School of Engineering.

**Corporate** 9586 58th Place | Kenosha, WI 53144 USA  
P +1 (262) 654-6006 | E info@centrisys.com

**Global Presence** North America | South America | Europe | Middle East | China

### Providing Media Commentary On:

- **Smart Design Solutions:** understanding the importance of designing systems that can be serviced quickly, using non-proprietary parts which increases uptime of the equipment
- **Customized Electric Panel Systems:** designing, programming and supporting application, customer and country specific panel requirements
- Supply chain supplier support and partners in finding innovative options for upgrading older control panels
- Importance of evaluating industry advances vs. tried and true panel design
- Electrical standards and approved codes of practice within a global footprint; supporting multiple program languages

### Awards

- 2018 Utility of the Future Today Recognition Program for the Kenosha WWTP Optimization Project
- 2017 W&WD Top Project for the Kenosha WWTP Optimization Project
- 2017 ACEC Grand Award Winner for the Kenosha WWTP Optimization Project
- 2013 Centrisys MVP of the Year
- 2013 WEF Innovative Technology Award – THK Thickening System
- 2008 Wisconsin Manufacturer of the Year

### Affiliations

- Water Environment Federation (WEF)
- Milwaukee Water Council
- Kenosha Area Business Alliance
- Kenosha Area Chamber of Commerce

### Media Contact

Michele Whitfield

P +1 (262) 654-6006 | E marketing@centrisys.us



ISO 9001:2015

BGH2018.v3EN

# George Kueppers

Vice President of Production

## Issue:

Uptime is critical for municipal wastewater treatment plants. For a facility tasked with processing millions, sometimes billions, of gallons of wastewater every day, equipment failure is not an option. To ensure maximum uptime for dewatering centrifuge systems, plant operators must consider a variety of design, construction and operational factors that contribute to reliability.

### Water and Wastewater Treatment Publications

can turn to George Kueppers for a refreshing perspective on how to get the most life and performance out of wastewater treatment equipment. A veteran of the wastewater industry for almost 30 years, Kueppers has been with Centrisys since its founding in 1987, helping to build the company's tradition of durable, efficient equipment.



**George Kueppers**  
Vice President of Production

## Biography

Michael Kopper, Centrisys C.E.O. and founder, met Kuepper at the local fitness club. At that time, Kueppers did not know what a centrifuge was, let alone that he would play a key role to help create a global company leading the industry with innovative centrifuge designs. After its founding as an decanter centrifuge service provider, Centrisys began to manufacture its own brand of decanter centrifuges. The company studied centrifuges – what worked, what did not and why. This expertise translated into the ability to service any make or model of decanter centrifuges.

As Centrisys grew, Kueppers' team maintained the service integrity and responsiveness of a small startup, a quality he credits for the company's strong growth. Under Kueppers' direction, the company built a massive domestic supplier network that provides 85 percent of its centrifuge parts and maintains a substantial inventory to ensure unparalleled service around the world. Kueppers also works hand-in-hand with the Centrisys engineering team to re-engineer and optimize parts for all brands of decanter centrifuges.

## Providing Media Commentary On:

- Benefits of hydraulic scroll drive technology versus standard gearbox back drive systems
- Repair and optimization techniques of all brands of decanter centrifuges
- Maintenance tips to keep a centrifuge running efficiently
- How to build a strong repair facility and field service team
- The manufacturing skills gap – skilled mechanics are necessary for the future of U.S. manufacturing
- The importance of a strong inventory and supply chain network of part suppliers to insure customer support
- How to build a parts and component design library to be competitive as a supplier in decanter centrifuge service

## Awards

- 2018 Utility of the Future Today Recognition Program for the Kenosha WWTP Optimization Project
- 2017 W&WD Top Project for the Kenosha WWTP Optimization Project
- 2017 ACEC Grand Award Winner for the Kenosha WWTP Optimization Project
- 2013 WEF Innovative Technology Award – THK Thickening System
- 2008 Wisconsin Manufacturer of the Year

## Affiliations

- Water Environment Federation (WEF)
- Milwaukee Water Council
- Kenosha Area Business Alliance
- Kenosha Area Chamber of Commerce

## Media Contact

Michele Whitfield

P +1 (262) 654-6006 | E marketing@centrisys.us

**Corporate** 9586 58th Place | Kenosha, WI 53144 USA  
P +1 (262) 654-6006 E info@centrisys.com

**Global Presence** North America | South America | Europe | Middle East | China



ISO 9001:2015

BGK2018.v3EN

# Luis Garza

## Mechanical Engineer Director

### Issue:

Many municipalities are using legacy wastewater treatment systems that are three or four decades old. While these systems can still get the job done, advancements in the technology offer significant opportunities to improve efficiency, performance, reliability and cost savings. By attacking these challenges head on, forward-thinking engineers are helping to advance the industry.

### Water and Wastewater Treatment Publications

can turn to Luis Garza for a first-hand account of how innovative centrifuge technology is designed from concept to installation. Garza has 20 years of unparalleled experience in decanter centrifuge innovation and design. He played an integral role in moving the company from a small startup to a globally recognized brand.

### Biography

Garza's career in engineering took root 20 years ago when he walked into the Centrisys office to apply for a mechanical draftsman job. Michael Kopper, CEO and Founder, asked Garza to do the following – draw the flights on a scroll without having to draw each individual flight. Without knowing what a centrifuge was, let alone a scroll and flights, Garza managed to complete the task within four days; he was hired. Today, Garza has designed close to 2,400 centrifuges.

Designing custom engineered solutions is Garza's forte. He works closely with engineers and customers to develop dewatering systems to fit within the specifications of each project. Garza and his team, of seven mechanical engineers, work side-by-side with the electrical, process and service teams to develop the most rugged centrifuge in the industry today.



**Luis Garza**  
Mechanical Engineer  
Director

### Providing Media Commentary On:

- Bridging the gap between innovative concepts and common-sense engineering practices
- Evolution of centrifuge design over the last 20 years
- Key features and benefits of working with SOLIDWORKS mechanical design solutions

### Awards

- 2018 Utility of the Future Today Recognition Program for the Kenosha WWTP Optimization Project
- 2017 W&WD Top Project for the Kenosha WWTP Optimization Project
- 2017 ACEC Grand Award Winner for the Kenosha WWTP Optimization Project
- 2013 WEF Innovative Technology Award – THK Thickening System
- 2008 Wisconsin Manufacturer of the Year

### Affiliations

- Water Environment Federation (WEF)
- Milwaukee Water Council
- Kenosha Area Business Alliance
- Kenosha Area Chamber of Commerce

### Media Contact

Michele Whitfield

P +1 (262) 654-6006 | E marketing@centrisys.us

**Corporate** 9586 58th Place | Kenosha, WI 53144 USA  
P +1 (262) 654-6006 E info@centrisys.com

**Global Presence** North America | South America | Europe | Middle East | China



ISO 9001:2015

BLG2018v3EN

# Michael Kopper

C.E.O. and Founder

## Issue:

Innovating new wastewater treatment technology is critical world wide. The right expertise and focus is needed from pioneering companies to improve efficiency, performance and cost savings. Forward-looking leaders help create breakthroughs and make a positive impact on people, the environment and lead the world to a more sustainable future.

### Water and Wastewater Treatment Publications

can turn to Centrisys C.E.O. and Founder Michael Kopper for deeper insights on the latest trends and technology in the industry. A charismatic leader and passionate speaker, Kopper is at the forefront of global efforts developing new innovative biosolids treatment processes and infuses a spirit of ingenuity in his commentary.



**Michael Kopper**  
C.E.O. and Founder

## Biography

With a technical background that spans 40 years, Kopper is a centrifuge manufacturing and service expert. Kopper began his career in the dewatering industry as a 14-year-old apprentice at centrifuge manufacturer Humboldt-Wedag. After earning an engineering degree from a Cologne, Germany technical college, Kopper supervised the startup, operations and process refinements of Humboldt centrifuges around the world.

After many years of working in centrifuge operation and service with Humboldt, Kopper founded Centrisys in 1987 as a repair and optimization company for decanter centrifuges. In 1989, a municipal customer could not wait for a decanter centrifuge to be manufactured overseas. Michael and his team built their first decanter centrifuge utilizing their dewatering know-how and optimization expertise with what did and did not work from the different brands of centrifuges they repaired throughout the years. This innovation foundation still drives the company today, as Kopper leads Centrisys with problem-solving ideas that advance the industry.

## Providing Media Commentary On:

- Building an innovative, global team from the ground up
- Leading a U.S.A. manufacturer and competing against dominant industry players domestically and worldwide
- Dewatering and process innovation through problem solving for municipal and industrial wastewater applications
- Wastewater treatment equipment design
- Wastewater treatment process
- Waste to energy environmental solutions now and in the future
- Centrifuges used in oil and gas applications, including oil recovery from waste
- Exporting into global economies with U.S.A. manufactured products

## Awards

- 2018 Utility of the Future Today Recognition Program for the Kenosha WWTP Optimization Project
- 2017 W&WD Top Project for the Kenosha WWTP Optimization Project
- 2017 ACEC Grand Award Winner for the Kenosha WWTP Optimization Project
- 2013 WEF Innovative Technology Award – THK Thickening System
- 2013 Kenosha County Entrepreneur of the Year
- 2012 Milwaukee BizTimes Bravo! Entrepreneur Award
- 2008 Wisconsin Manufacturer of the Year

## Affiliations

- Water Environment Federation (WEF)
- Milwaukee Water Council
- Kenosha Area Business Alliance
- Kenosha Area Chamber of Commerce

## Media Contact

Michele Whitfield

P +1 (262) 654-6006 | E marketing@centrisys.us

**Corporate** 9586 58th Place | Kenosha, WI 53144 USA  
P +1 (262) 654-6006 E info@centrisys.com

**Global Presence** North America | South America | Europe | Middle East | China



ISO 9001:2015

BMK2018v3EN

# Robert Greidanus

## Manufacturing Director

### Issue:

Manufacturing in the U.S. is a vital sector, although its importance to the U.S. economy has declined for the past forty years. The right expertise and focus is needed for U.S.A. manufacturers to stay relevant in a capital-cost intense environment. To remain competitive and retain its leadership in a global economy, American manufacturers need to be smarter, safer and more environmentally sustainable.

### Water and Wastewater Treatment Publications

can turn to Bob Greidanus for “feet on the ground” insight into what it takes to build long and short term manufacturing strategies. Working with other U.S. supply chain partners, Greidanus helps to develop consistent goals for the good of all companies involved. He can discuss first-hand what it means to be the mid-size underdog in an industry full of Über large global corporations and still be highly competitive and profitable.

### Biography

When Greidanus noticed Centrisys’ location expanding to another building in 2001, he dropped off his resume and was offered a position later that day. It quickly became apparent to Michael Kopper, Centrisys C.E.O. and Founder, that Greidanus had more to offer. Greidanus quickly rose up the company ranks to his current position as Director of Manufacturing. Greidanus was a valued team member in the integration of the current ERP system upgrade that helps manage costs, materials, procurement and quality control. Over his 15 years of employment at Centrisys, Greidanus has managed up to 30 employees across 11 departments ensuring productivity timelines, costs and quality measures are consistently met or exceeded.

Greidanus earned a Bachelor of Science from DeVry University in Technical Management with a concentration on Industrial Project Management (graduating Summa Cum Laude) and an A.A.S. Degree in Network Communication from Gateway Technical College.



**Robert Greidanus**  
Manufacturing Director

### Providing Media Commentary On:

- Quality as a competitive advantage
- Having a consistent manufacturing process and a harmonized approach to safety, including risk based management of issues, suppliers, standards and collaboration
- Closing the manufacturing skills gap by training the next generation of workers who lack the skills and technical knowledge needed for moving U.S. manufacturing into the future
- The increasing challenges of supply chain management and strategy
- Increasing productivity with shorter lead times while managing inventory responsibly; keep inventory discrepancies as low as possible
- Common sense approach to global sourcing as a U.S.A. manufacturer

### Awards

- 2018 Utility of the Future Today Recognition Program for the Kenosha WWTP Optimization Project
- 2017 W&WD Top Project for the Kenosha WWTP Optimization Project
- 2017 ACEC Grand Award Winner for the Kenosha WWTP Optimization Project
- 2015 Centrisys MVP of the Year
- 2013 WEF Innovative Technology Award – THK Thickening System
- 2008 Wisconsin Manufacturer of the Year

### Affiliations

- Water Environment Federation (WEF)
- Milwaukee Water Council
- Kenosha Area Business Alliance
- Kenosha Area Chamber of Commerce

### Media Contact

Michele Whitfield

P +1 (262) 654-6006 | E marketing@centrisys.us

**Corporate** 9586 58th Place | Kenosha, WI 53144 USA  
P +1 (262) 654-6006 E info@centrisys.com

**Global Presence** North America | South America | Europe | Middle East | China



ISO 9001:2015

BRG2018v3EN

# Gerhard Forstner President

## Issue:

Many municipalities use legacy wastewater treatment systems that are three or four decades old. With new processes emerging, these technological advancements offer opportunities to improve the plant's efficiency and cost savings.

**Wastewater Treatment Publications** can turn to CNP President Gerhard Forstner as he has over twenty years of experience in taking innovative biosolids processes and equipment to the market. Forstner is instrumental in positioning CNP - Technology Water and Biosolids as a leader in nutrient recovery and sludge optimization solutions. He led the CNP team as the design-build developer on the Kenosha Energy Optimization Project and was a key contributor to its success.



**Gerhard Forstner**  
President

## Biography

Forstner joined CNP in 2013 and leads CNP in its phosphorous recovery and Thermo-Chemical Hydrolysis Process initiatives. Forstner is highly experienced in primary, secondary and tertiary treatment systems and has worked in both the municipal and industrial wastewater industries. He has a thorough understanding of biosolids treatment systems, including thermal hydrolysis systems, drying and gasification technologies. He leads a team of industry veterans who have over five decades of experience in engineering, process design and project management.

A native of Austria, Forstner graduated from Kapfenberg Technical College in Austria with an Electrical Engineering degree. He holds a MBA from Queens University in Charlotte, NC. Forstner began working in wastewater, water and sludge treatment in 2001. He gained valuable industry knowledge while working as a: application engineer, project manager, regional sales manager and the President of Huber Technology, U.S.A.

## Providing Media Commentary On:

- How to properly optimize existing processes
- Turn wastewater treatment plants from an energy consumer to an energy provider
- Design-Build a cost-effective and eco-friendly solution to biosolids handling, processing and disposal

## Awards

- 2018 Utility of the Future Today Recognition Program for the Kenosha WWTP Optimization Project (PONDUS)
- 2017 W&WD Top Project for the Kenosha WWTP Optimization Project (PONDUS)
- 2017 ACEC Grand Award Winner for the Kenosha WWTP Optimization Project (PONDUS)
- 2016 U.S. Environmental Protection Agency (EPA) Nutrient Recycling Challenge Award (AirPrex)
- 2015 Green Tec Award (AirPrex)

## Affiliations

- Water Environment Federation (WEF)
- The Water Research Foundation (WRF)
- Leaders Innovation Forum for Technology (LIFT)
- Milwaukee Water Council
- Kenosha Area Business Alliance
- Kenosha Area Chamber of Commerce

## Media Contact

Michele Whitfield

P +1 (262) 654-6006 | E marketing@centrisys.us

**Corporate** 9586 58th Place | Kenosha, WI 53144 USA  
P +1 (262) 654-6006 E info@cnp-tec.us

**Global Presence** North America | South America | Europe | Middle East | China



# Joseph Hughes

Project Manager

## Issue:

Many municipalities use legacy wastewater treatment systems that are over three decades old. With new biosolids processes emerging, forward thinking plants can improve their solids management, reduce biosolids volume, generate on-site electricity and produce Class A biosolids. These innovative treatment advancements offer opportunities to improve efficiencies while reducing costs and offer an eco-friendly solution to sludge handling.

**Wastewater Treatment Publications** can turn to Joseph Hughes, CNP Project Manager, on how to work through the short term challenges of integrating biosolids innovation to meet the long term goals of a treatment plant.

## Biography

Hughes joined the CNP team in 2014 and has over 30 years of experience working with biosolids equipment and processes. He is the current CNP Project Manager working directly with the Kenosha treatment plant, consulting engineers and the contractor to integrate and optimize multiple technologies to meet a range of performance requirements. The Kenosha Water Utility (KWU) has the first U.S. installation of PONDUS (TCHP). KWU received a We Energies renewable energy grant due to the biogas production increase from the PONDUS process.

At the 2017 WEF Residuals and Biosolids Conference, Hughes will co-present the paper "Kenosha's Energy-Optimized Resource Recovery System." He details the challenges of optimizing a range of complex technologies to work fluidly together, including: Centrisys' decanter centrifuges (sludge dewatering and thickening), anaerobic digesters, boiler, hot water system, Combined Heat and Power units (CHP), a biogas conditioning system (PONDUS - TCHP) and a low-temperature belt dryer.

Hughes earned his Bachelor of Science in Environmental Engineering from Pennsylvania State University.



**Joseph Hughes, P.E.**  
Project Manager

## Providing Media Commentary On:

- Installing innovative biosolids equipment while upgrading the existing equipment
- Working with wastewater treatment plants from design to equipment optimization and meet the performance requirements of the plant
- How to be green and increase biogas production with PONDUS, a Thermo-Chemical Hydrolysis Process (TCHP)

## Awards

- 2018 Utility of the Future Today Recognition Program for the Kenosha WWTP Optimization Project (PONDUS)
- 2017 ACEC Grand Award Winner for the Kenosha WWTP Optimization Project (PONDUS)
- 2016 U.S. Environmental Protection Agency (EPA) Nutrient Recycling Challenge Award (AirPrex)
- 2015 Green Tec Award (AirPrex)

## Affiliations

- Water Environment Federation (WEF)
- The Water Research Foundation (WRF)
- Leaders Innovation Forum for Technology (LIFT)
- Milwaukee Water Council
- Kenosha Area Business Alliance
- Kenosha Area Chamber of Commerce

## Media Contact

Michele Whitfield

P +1 (262) 654-6006 | E marketing@centrisys.us

**Corporate** 9586 58th Place | Kenosha, WI 53144 USA  
P +1 (262) 654-6006 E info@cnp-tec.us

**Global Presence** North America | South America | Europe | Middle East | China

# Menachem Tabanpour

VP of Business Development

## Issue:

High levels of orthophosphates at many wastewater treatment plants cause operational challenges that increase costs and decrease operational efficiencies. These include struvite issues in the methane digester, increased polymer consumption during dewatering, reduced dewaterability of the plant's sludge and challenges meeting NPDES permits.

Phosphorus removal and recovery is one of, if not the, hottest topics in the wastewater biosolids industry today. Tightening regulations for both land application and sale of biosolids have water reclamation professionals eager to evaluate technologies. They need to remove nuisance phosphorus from biosolids in a cost-effective and sustainable manner.

**Wastewater Treatment Publications** can turn to Menachem Tabanpour, VP of Business Development, who has over 15 years of experience with wastewater resource recovery.

## Biography

Tabanpour joined CNP as the VP of business development through a partnership with Nutrient Recovery and Upcycling (NRU). The partnership was created to commercialize the CalPrex™ high-efficiency pre-digestion phosphorus recovery. Tabanpour's nutrient recovery technology experience and knowledge dates back to 2002, when he began research on controlled struvite crystallization at the University of Wisconsin-Madison. Since then, he worked on numerous projects related to nutrient upcycling and leads the development of phosphorus and nitrogen recovery technologies at CNP.

For over five years, Tabanpour led the development of CalPrex with the goal of bringing a novel and economically sustainable technology to market. CalPrex is a technology that benefits wastewater treatment facilities, farmers and the environment.



**Menachem Tabanpour**  
VP of Business Development

## Providing Media Commentary On:

- Phosphorus recovery and nutrient re-use
- Design-build cost-effective and environmentally responsible solutions for phosphorus
- Integrating nutrient recovery into existing facilities
- Resource upcycling
- Sustainable nutrient management

## Affiliations

- Water Environment Federation (WEF)
- The Water Research Foundation (WRF)
- Leaders Innovation Forum for Technology (LIFT)
- Nutrient Recovery and Upcycling (NRU)  
President and Co-Founder

## Media Contact

Michele Whitfield

P +1 (262) 654-6006 | E [marketing@centrisys.us](mailto:marketing@centrisys.us)

**Corporate** 9586 58th Place | Kenosha, WI 53144 USA  
P +1 (262) 654-6006 E [info@cnp-tec.us](mailto:info@cnp-tec.us)

**Global Presence** North America | South America | Europe | Middle East | China